

TECHNICAL MANUAL

TRANSPORTABILITY GUIDANCE

HOWITZER, LIGHT, SELF-PROPELLED: 105-MM, M108
(NSN 2350-00-440-8810)

HOWITZER, MEDIUM, SELF-PROPELLED: 155-MM, M109
(NSN 2350-00-440-8811)

HOWITZER, MEDIUM, SELF-PROPELLED:
155-MM, M109A1
(NSN 2350-00-485-9662)

TECHNICAL MANUAL }
 No. 55-2350-217-15-1 }

HEADQUARTERS
 DEPARTMENT OF THE ARMY
 WASHINGTON, D. C., 15 May 1975

TRANSPORTABILITY GUIDANCE

HOWITZER, LIGHT, SELF-PROPELLED: 105-MM, M108
(NSN 2350-00-440-8810)

HOWITZER, MEDIUM, SELF-PROPELLED: 155-MM, M109
(NSN 2350-00-440-8811)

HOWITZER, MEDIUM, SELF-PROPELLED: 155-MM, M109A1
(NSN 2350-00-485-9662)

	Paragraph	Page
CHAPTER	1. INTRODUCTION	
	Purpose and Scope	1-1 1-1
	Reporting of Recommendations and Comments	1-2 1-1
	Safety.	1-3 1-1
	Definitions of Warnings, Cautions, and Notes.	1-4 1-1
	2. TRANSPORTABILITY DATA	
Section	I. GENERAL	
	Scope	2-1 2-1
	Descriptions	2-2 2-1
	II. CHARACTERISTICS AND RELATED DATA	
	General	2-3 2-3
	Side and Rear Elevation Drawings	2-4 2-3
	Reduced Configuration	2-5 2-9
	Unusual Characteristics	2-6 2-9
	Hazardous and Dangerous Characteristics	2-7 2-9
	Sensitivity.	2-8 2-9
	CONUS Freight Classification	2-9 2-9
CHAPTER	3. SAFETY	
	General	3-1 3-1
	Specific Safety Requirements.	3-2 3-1
	4. AIR TRANSPORTABILITY GUIDANCE	
	Scope	4-1 4-1
	Maximum Utilization of Aircraft	4-2 4-1
	Safety.	4-3 4-1
	Preparation of Vehicle	4-4 4-1
	Transport by US Air Force Aircraft	4-5 4-1
	Transport by US Army Aircraft.	4-6 4-3
CHAPTER	5. HIGHWAY TRANSPORTABILITY GUIDANCE	
Section	I. GENERAL	
	Scope	5-1 5-1
	Safety	5-2 5-1
	General	5-3 5-1
	II. TRANSPORT BY SEMITRAILER	
	Preparation	5-4 5-1
	Transport on Semitrailer	5-5 5-1
	Transport on Semitrailer, M747	5-6 5-1

*This manual supersedes TM 55-2350-217-10-1, 21 January 1966.

	Paragraph	Page
CHAPTER	6. MARINE AND TERMINAL TRANSPORTABILITY GUIDANCE	
Section	I. GENERAL	
	Scope	6-1 6-1
	Safety	6-2 6-1
	Water Shipment	6-3 6-1
	II. LOADING AND SECURING	
	General Rules	6-4 6-1
	Barges and Lighters	6-5 6-5
	Landing Ships, Landing Craft, and Amphibians	6-6 6-6
	Barge-Type Ships (LASH) (SEABEE)	6-7 6-5
CHAPTER	7. RAIL TRANSPORTABILITY GUIDANCE	
Section	I. GENERAL	
	Scope	7-1 7-1
	Maximum Utilization of Railcars	7-2 7-1
	II. TRANSPORT ON CONUS RAILWAYS	
	General	7-3 7-1
	Preparation	7-4 7-1
	Loading on General-Purpose Flatcars	7-5 7-1
	Loading on Special-Purpose Flatcars	7-6 7-1
	III. TRANSPORT ON FOREIGN RAILWAYS	
	General	7-7 7-9
	Transport on US Army-Owned Foreign Service Flatcars	7-8 7-9
APPENDIX	A. CONVERSION TABLES	A-1
	B. REFERENCES	B-1

LIST OF ILLUSTRATIONS

Figure number	Title	Page
2-1	Howitzer, light, self-propelled, 105-mm, M108	2-1
2-2	Howitzer, medium, self-propelled, 155-mm, M109	2-2
2-3	Howitzer, medium, self-propelled, 155-mm, M109A1	2-2
2-4	Side elevation, M108	2-4
2-5	Rear elevation, M108	2-5
2-6	Side elevation, M109	2-6
2-7	Side elevation, M109A1	2-7
2-8	Rear elevation, M109 and M109A1	2-8
4-1	Tiedown diagram for M108, M109, and M109A1 in C-5 aircraft	4-2
5-1	Blocking and tiedown diagram of typical howitzer, M109 on semitrailer, M747	5-3
5-2	Turning diagram for M109 loaded on semitrailer, M747, towed by truck-tractor, M123E2	5-4
6-1	Lifting diagram for M108 using four legged bridle sling and one spreader bar	6-2
6-2	Typical blocking and tiedown for howitzer, M108, in general cargo vessel	6-4
6-3	Loading of four howitzers, M109A1, on LASH barge using wire rope, cable clamps, and turnbuckles with blocking between howitzers and howitzers to hull	6-7
6-4	Loading of five howitzers, M109, on LASH barge, using wire rope, cable clamps, and turnbuckles with blocking between howitzers and howitzers to hull	6-8
7-1	Blocking and tiedown diagram of typical howitzer, M109, on CONUS general-purpose flatcar (side view)	7-2
7-2	Blocking and tiedown diagram of typical howitzer, M109, on CONUS general-purpose flatcar (front view)	7-3
7-3	Blocking and tiedown detail diagram	7-4
7-4	Blocking and tiedown diagram of typical howitzer, M109A1, on CONUS HTTX or similar type flatcar (side view)	7-5
7-5	Blocking and tiedown diagram of typical howitzer, M109A1, on CONUS HTTX or similar type flatcar (front view)	7-6

CHAPTER 1

INTRODUCTION

1-1. Purpose and Scope

a. This manual provides transportability guidance for logistic handling and movement of the howitzers, self-propelled, full-tracked, M108, M109, and M109A1.

b. The intent of this manual is to provide transportation officers and other personnel responsible for movement or providing transportation services with information considered appropriate for safe transport. Significant technical and physical characteristics as well as safety considerations required for worldwide movement by the various modes of transportation are included. When considered appropriate, metric equivalents are given in parentheses following, dimensions or other measurements. Conversion tables are contained in appendix A.

1-2. Reporting of Recommendations and Comments

The reporting of errors, omissions, and recommendations for improving this manual by the individual user is encouraged. Reports should be submitted on DA Form 2028 (Recommended Changes to DA Publications and Blank Forms) and forwarded to Director, Military Traffic Management Command Transportation Engineering Agency, ATTN: MTT-TRP, P. O. Box 6276, Newport News, Virginia 23606.

NOTE

Attention is invited to the stamped and preaddressed tear-out questionnaire following appendix B. Request that this questionnaire be completed and mailed within 6 months of the manual publication date.

1-3. Safety

Appropriate precautionary measures required during movement of the howitzers are contained in chapter 3.

1-4. Definitions of Warnings, Cautions, and Notes

Throughout this manual, warnings, cautions, and notes emphasize important or critical guidance. They are used for the following conditions:

a. *Warning.* An operating procedure or practice that, if not correctly followed, could result in personal injury or loss of life.

b. *Caution.* An operating procedure or practice that, if not strictly observed, could result in damage to or destruction of equipment.

c. *Note.* An operating procedure or condition that must be emphasized.

CHAPTER 2

TRANSPORTABILITY DATA

Section I. GENERAL

2-1. Scope

This chapter provides a general description of the items, identification photographs, tabulated transportability characteristics, and data that are necessary for movement.

2-2. Descriptions

a. General. The howitzers, M108, M109, and M109A1, are full-tracked, self-propelled, armored, combat vehicles. They are powered by liquid-cooled, compression ignition engines. Power is transmitted to the final drive through a cross-drive transmission differential, steering, and braking unit. The vehicles are supported by a torsion bar suspension system.

b. M108 (fig 2-1). The M108 armament includes a 105-mm cannon, M103, mounted in a howitzer mount, M139, and a caliber .50 machine gun, M2, mounted on the commander's cupola.

c. M109 (fig 2-2). The M109 armament includes a 155-mm cannon, M126, mounted in a howitzer mount, M127, and a caliber .50 machine gun, M2, mounted on the commander's cupola.

d. M109A1 (fig 2-3). The M109A1 armament includes a 155-mm cannon, M126A1, mounted in a howitzer mount, M127, and a caliber .50 machine gun, M2, mounted on a commander's cupola.

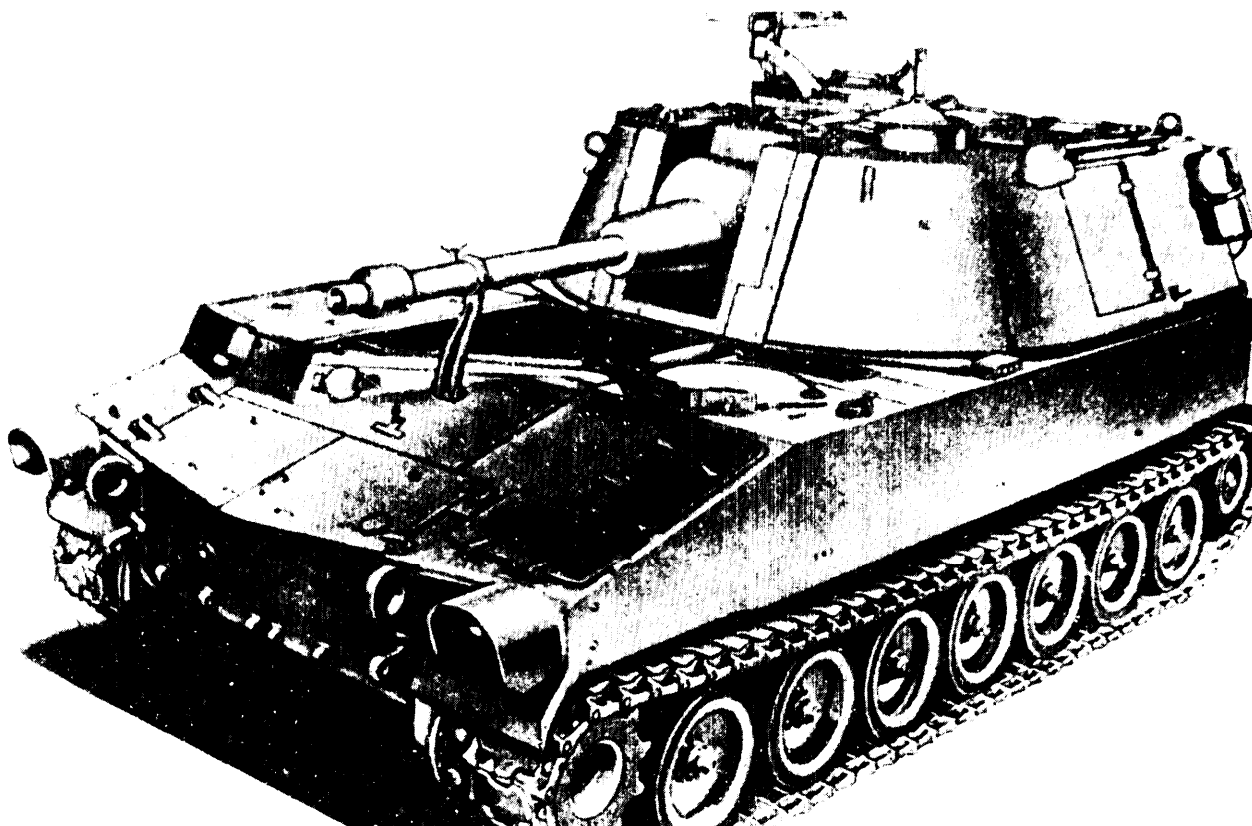

Figure 2-1. Howitzer, light, self-propelled, 105-mm, M108.



Figure 2-2. Howitzer, medium, self-propelled, 155-mm, M109.

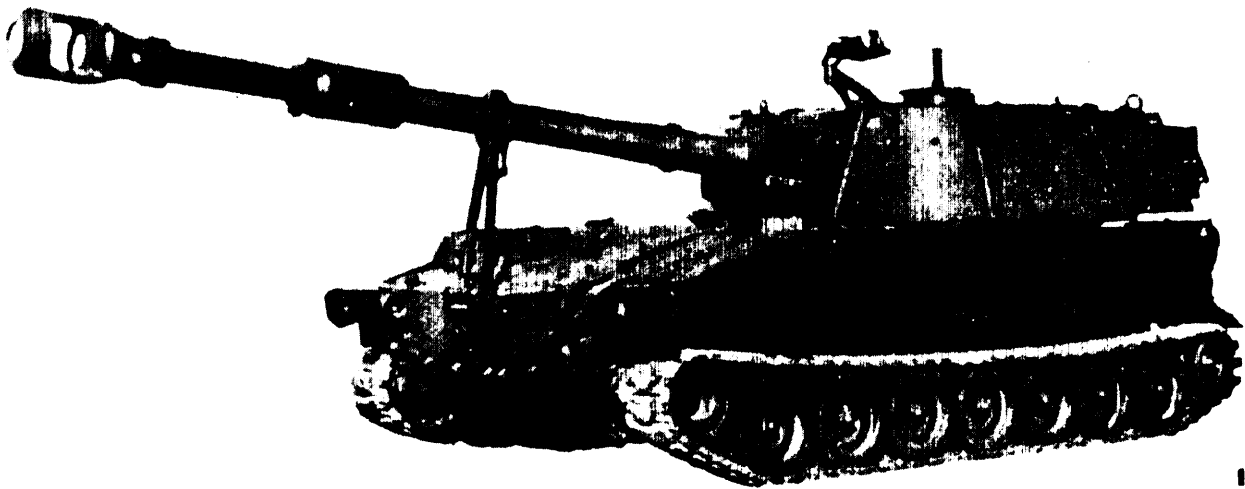

Figure 2-3. Howitzer, medium, self-propelled, 155-mm, M109A1.

Section II. CHARACTERISTICS AND RELATED DATA

2-3. General

Data contained in figures 2-4 through 2-8 and table 2-1 are applicable to model number or National Stock Number (NSN) shown. Changes in model number or NSN may affect transportability as related to guidance contained in this manual.

2-4. Side and Rear Elevation Drawings

Detailed side and rear elevation drawings (fig 2-4 through 2-8) provide data necessary for determining transportability of the howitzers by the various modes of transportation.

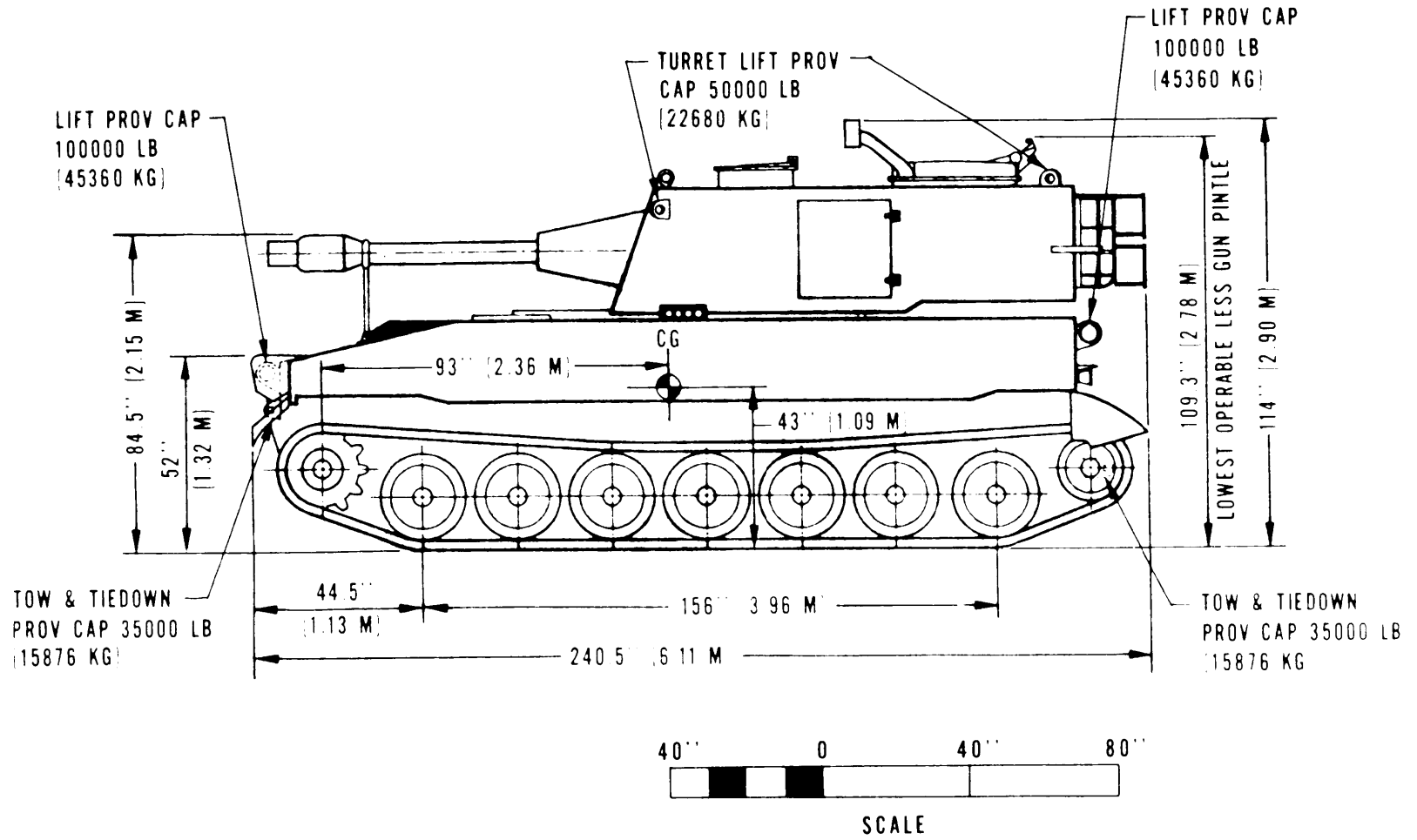

Figure 2-4. Side elevation, M108.

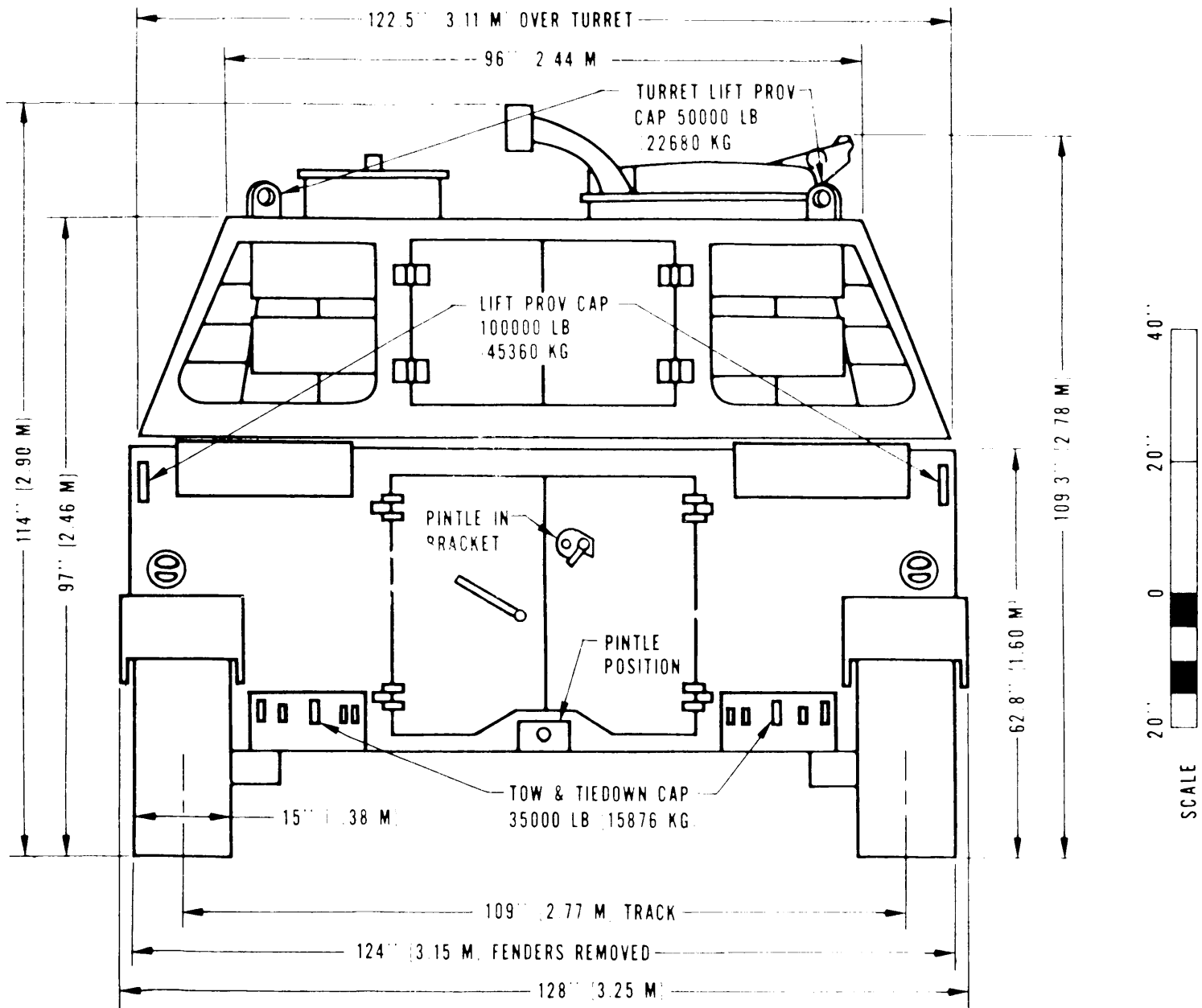

Figure 2-5. Rear elevation, M108.

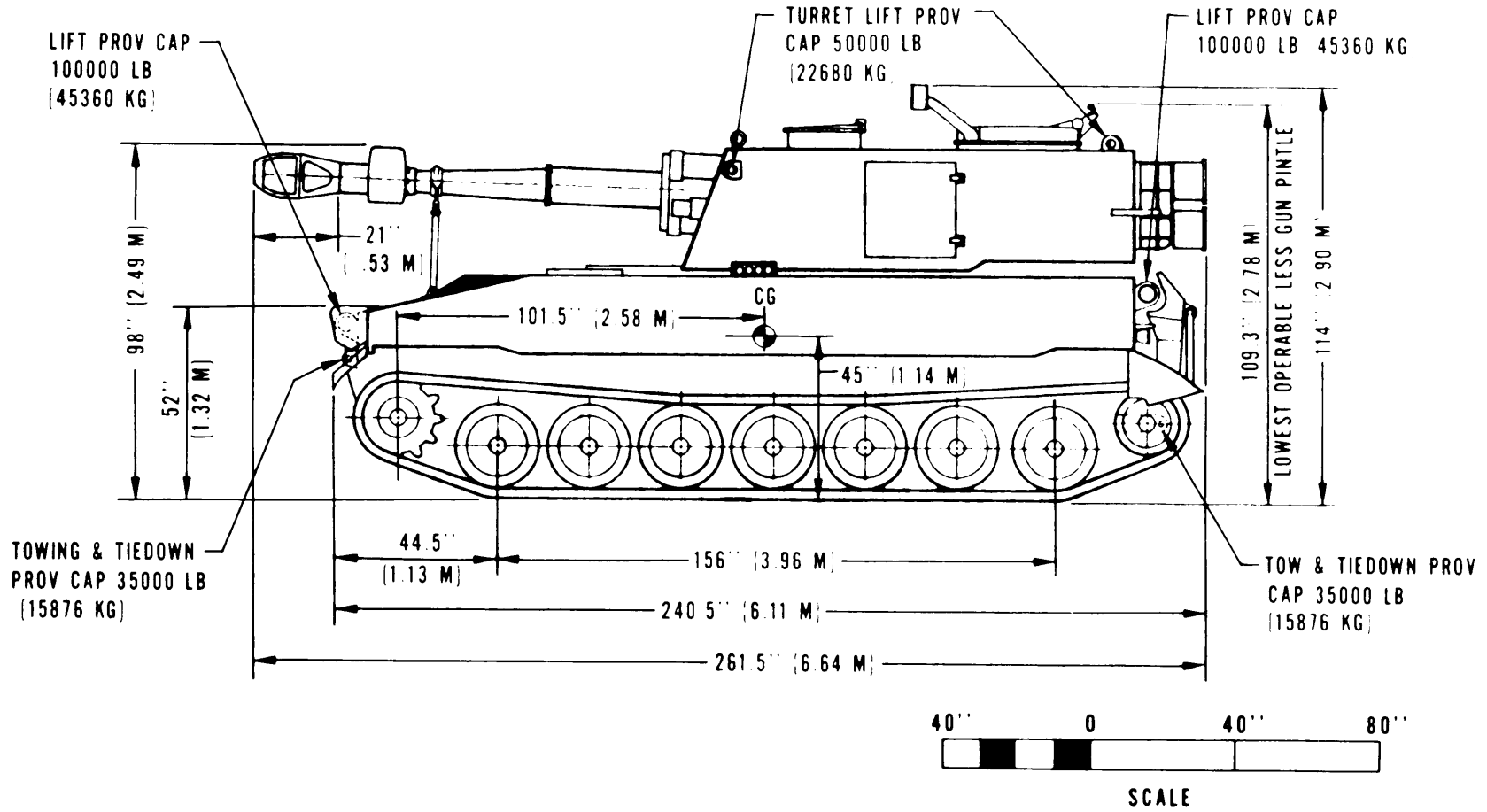

Figure 2-6. Side elevation, M109.

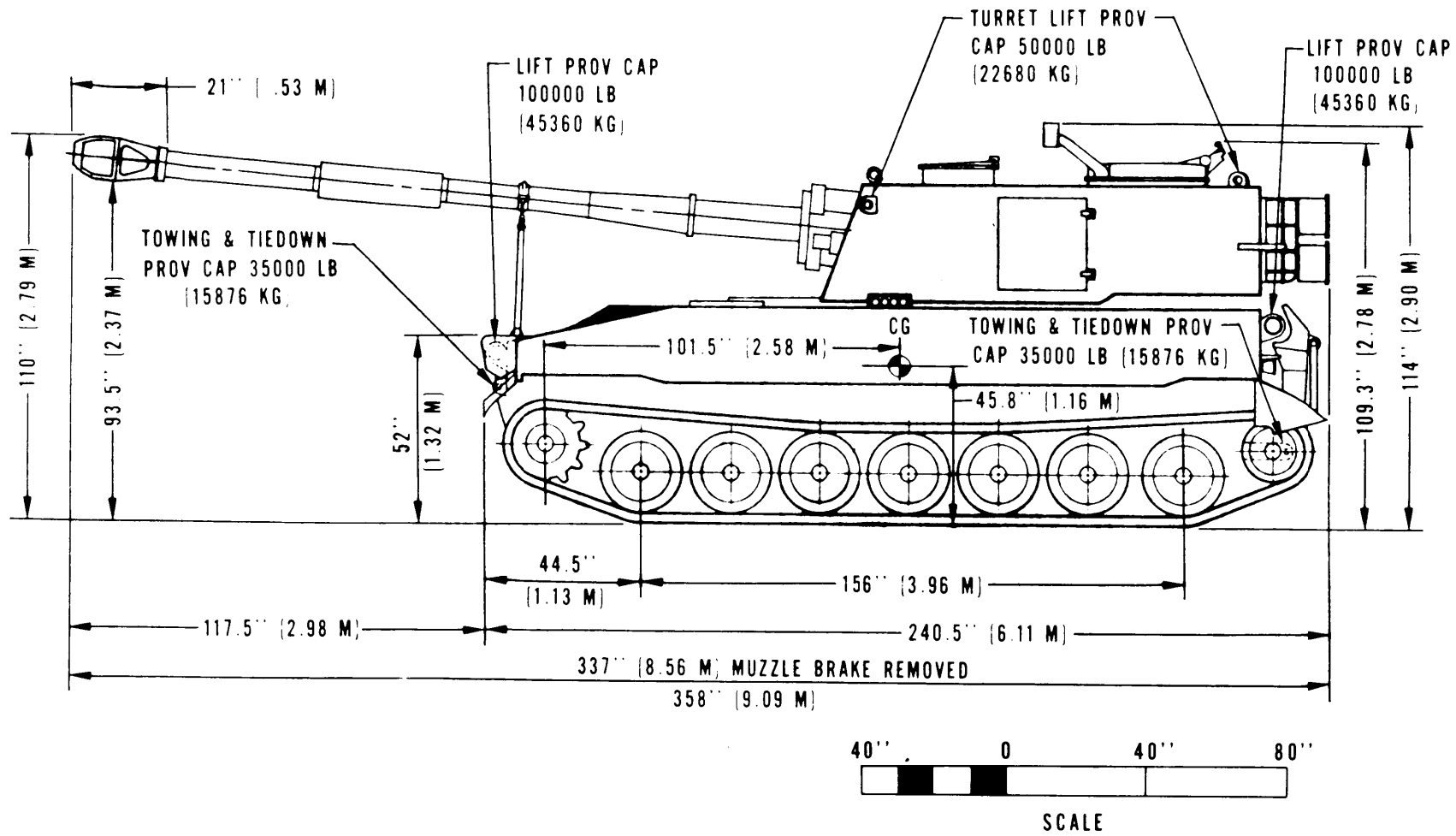

Figure 2-7. Side elevation, M109A1.

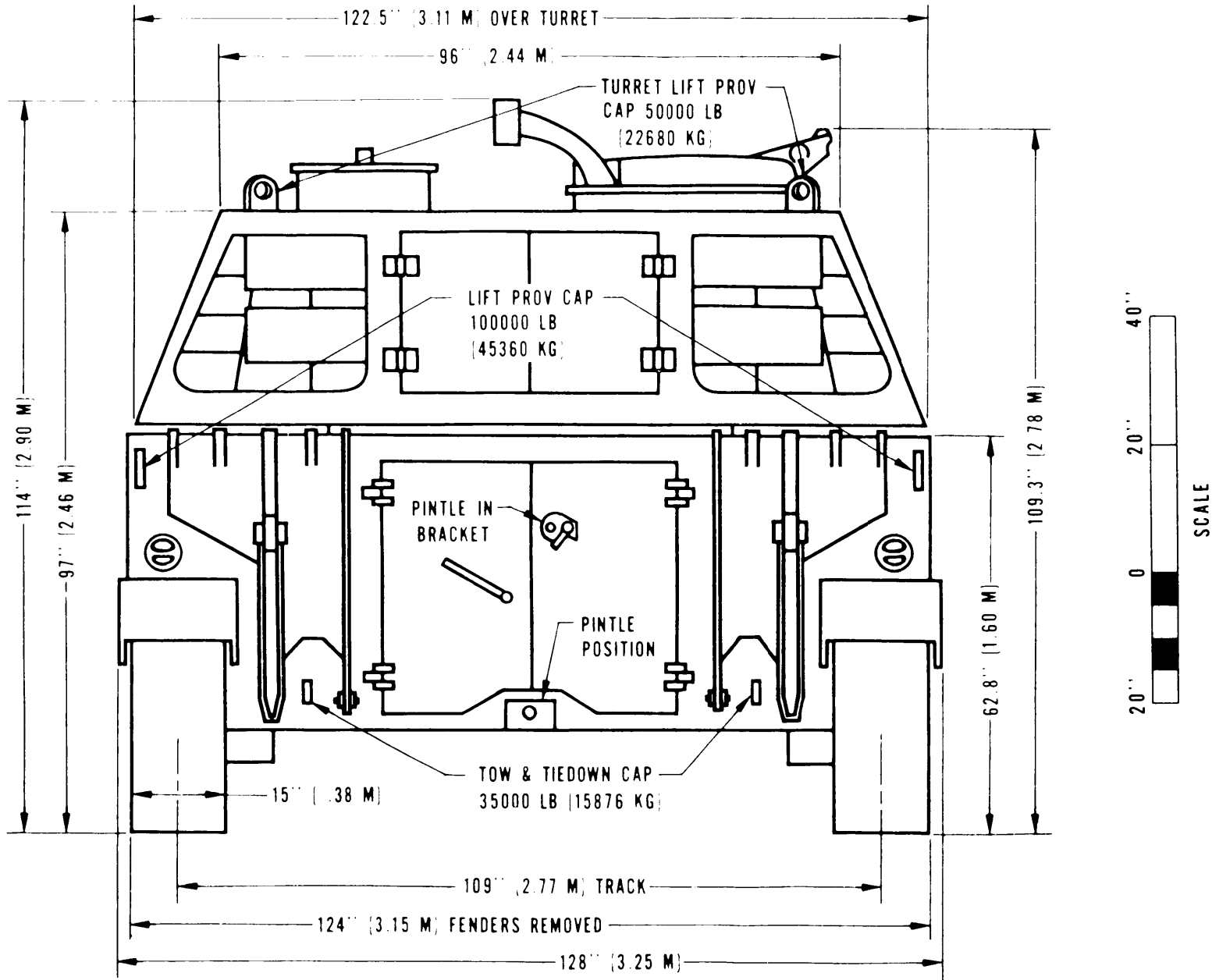

Figure 2-8. Rear elevation, M109 and M109A1.

2-5. Reduced Configuration

Transportation economies can be obtained by reducing each howitzer to its minimum dimensions for transport by ship. Removable items

such as machine gun mounts; front, rear, and side fenders; and muzzle brake (M109 and M109A1) should be removed and securely stowed within the howitzer.

Table 2-1. Characteristics and Related Data

Model	TOE LIN	National Stock No.	Weight, lb (kg)	Volume, cu ft (cu m)	
				Operational	Reduced
M108	K57255	2350-00-440-8810	40,087 (18,183)	2,031 (57.48)	1,886 (53.37)
M109	K57666	2350-00-440-8811	44,437 (20,157)	2,208 (62.49)	1,886 (53.37)
M109A1	K57666	2350-00-485-9662	46,800 (21,228)	3,023 (85.55)	2,643 (74.80)

2-6. Unusual Characteristics

The howitzers have no unusual characteristics that require that special attention be given to temperature, atmospheric pressure, or humidity variations during exposure to normal transportation.

2-7. Hazardous and Dangerous Characteristics

Unless the howitzers are shipped with ammunition under the provisions of Department of Transportation Special Permit No. 3498 (applicable to shipments in periods of actual national emergency), they will not present any hazardous or dangerous characteristics during exposure to normal transportation environments.

NOTE

Those regulations and/or transportation procedures normally associated with

vehicles containing diesel fuel will apply (app B).

2-8. Sensitivity

The howitzer is so designed that when restrained in accordance with the guidance contained in this manual it can withstand the shocks and vibrations associated with current transportation methods.

2-9. CONUS Freight Classification

Rail and motor freight classification descriptions and item numbers will be determined in accordance with chapter 211, AR 55-355. Proper classification and/or description of articles must be determined and provided on the bill of lading before shipments are released to carriers.

CHAPTER 3

SAFETY

3-1. General

General safety considerations and precautions for movement are as follows:

- a.* Check each vehicle to insure that all loose items are appropriately secured.
- b.* When backing a vehicle, insure that no personnel or obstacles are behind it.

WARNING

Fire extinguishers must be readily available during all loading and unloading operations.

WARNING

Proper ventilation must be provided during loading and unloading operations if vehicle engine is used. Prolonged inhalation of carbon monoxide fumes will produce adverse effects that could prove fatal.

3-2. Specific Safety Requirements

Pertinent safety requirements by individual modes of transport can be found, where applicable, in the appropriate chapters.

CHAPTER 4

AIR TRANSPORTABILITY GUIDANCE

4-1. Scope

This chapter provides transportability guidance for air movement of the howitzers, M108, M109, and M109A1. It covers significant technical and physical characteristics and safety considerations and prescribes the manpower, materials, and time required to prepare, load, and unload the howitzers as internal loads aboard US Air Force aircraft.

4-2. Maximum Utilization of Aircraft

The loads described in this chapter are not maximum loads. Total cargo loads and operating ranges in nautical miles are provided in AR 70-39.

4-3. Safety

In addition to the safety precautions contained in chapter 3, the following should be noted:

a. The activity offering the howitzer for air transport will notify the aircraft commander or his designated representative in the event ammunition or explosives are to be transported within the howitzer.

b. The vehicle fuel tanks must not be more than three-fourths full.

c. The howitzers must be restrained for air transport in accordance with the applicable procedures in section IV of Air Force TO 1C-5A-9. Procedures outlined in this manual are for general information.

WARNING

Fire extinguishers must be readily available during all loading and unloading operations.

WARNING

Proper ventilation must be provided when loading and unloading. Prolonged inhalation of carbon monoxide fumes may be fatal.

CAUTION

Do not allow vehicle to exceed 3 miles per hour inside aircraft or on loading ramps.

4-4. Preparation of Vehicle

a. Turret traverse and gun-elevating mechanism must be in travel position, locked, and wire-tied to prevent rotation. Spades on the M109 and M109A1 will be locked in the travel position.

b. Antennae must be tied down or removed, cupola in closed position, and loose equipment secured.

c. Machine gun and mount must be removed and secured.

4-5. Transport by US Air Force Aircraft

a. The howitzers, M108, M109, and M109A1, are air transportable only in C-5 aircraft.

b. The aircraft commander or his representative is responsible for insuring that the howitzers, M108, M109, and M109A1, are on/off loaded and properly secured in the aircraft in accordance with the criteria in section IV of TO 1C-5A-9.

c. Metal parts of the howitzer track must not make contact with the aircraft loading ramp or cargo compartment floor. Inconsistencies in the rubber track pad thicknesses and available contact area after prolonged vehicle operation prohibit on/off loading of howitzers without shoring. Adequate wood shoring for rolling and parking the vehicle will be used to protect the aircraft floor surfaces.

d. Restraint factors (g loads) for minimum acceptable conditions specified for crew and passenger safety in the event of a controlled emergency landing are specified in AR 70-39 and TO 1C-5A-9. Tiedown diagram (fig 4-1) and data table (table 4-1) are based on acceptable methods and can be used as a guide. Figure 4-1 shows a representative pattern. Table 4-1 lists the tiedown devices required (provided aboard aircraft), tiedown points on the howitzer, and corresponding fittings on the aircraft to which devices are secured.

e. When howitzer has been positioned aboard the aircraft, the transmission should be placed in neutral and the parking brakes set.

f. Four men can prepare, load, and tie down one howitzer in approximately 45 minutes. Three men can remove tiedowns and unload one howitzer in approximately 15 minutes.

WARNING

Consult TM 38-250 (AFM 71-4) to insure compatibility of any cargo being considered for loading with the howitzer.

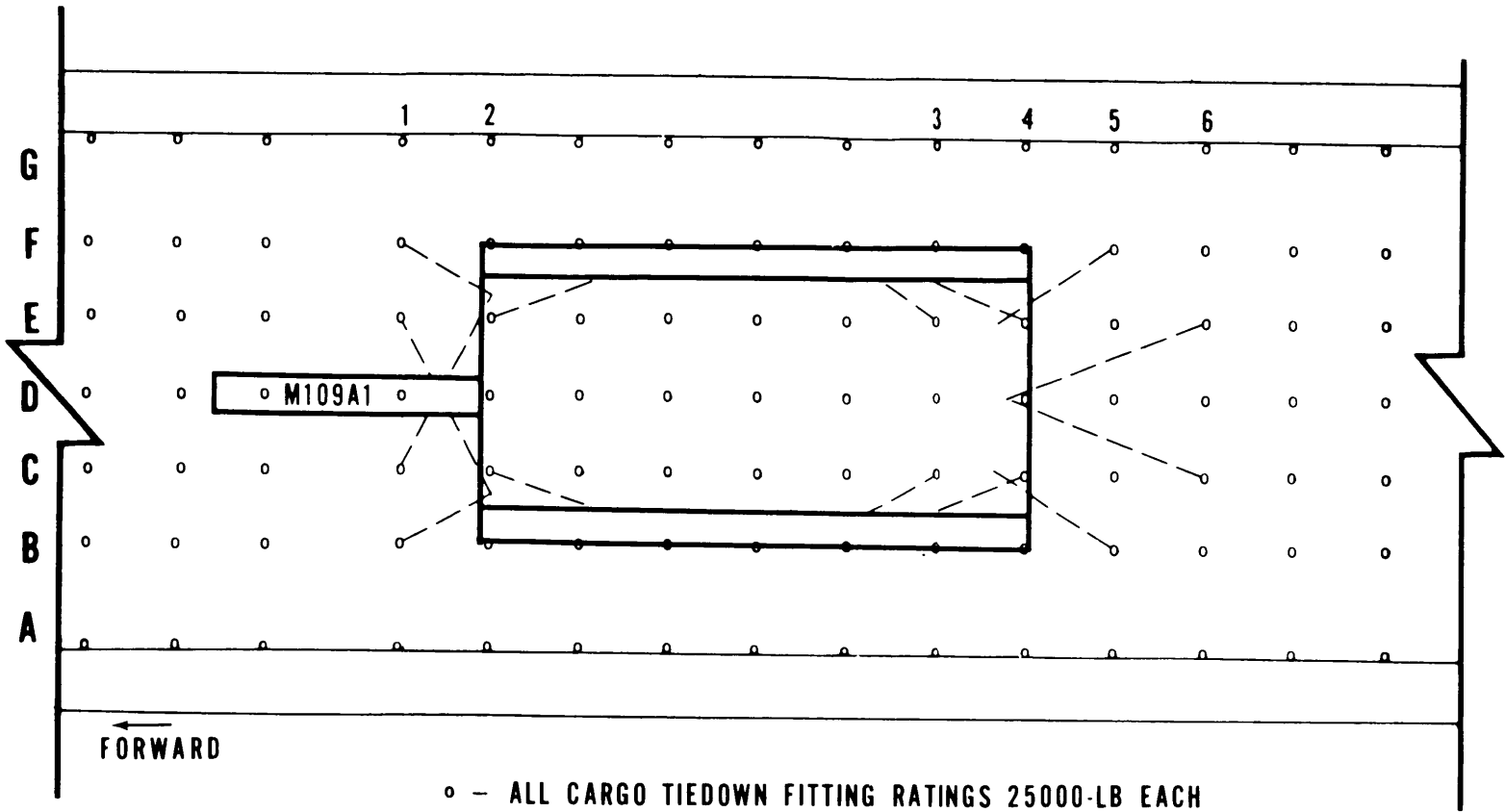

Figure 4-1. Tiedown diagram for M108, M109, and M109A1 in C-5 aircraft.

4-6. Transport by US Army Aircraft

The howitzers, M108, M109, and M109A1, exceed the size and weight limitations for internal or

external transport by US Army fixed-wing or rotary-wing aircraft.

Table 4-1. Tiedown Data for M108, M109, and M109A1 in C-5 Aircraft

Tiedown fitting		Tiedown device *		Attach to item
Designation	capacity in 1,000 lb	type	capacity in 1,000 lb	
B1	25	MB-2	25	Left tiedown point
F1	25	MB-2	25	Right tiedown point
C1	25	MB-2	25	Right tiedown point
E1	25	MB-2	25	Left tiedown point
C2	25	MB-2	25	Left No. 1 road wheel arm
E2	25	MB-2	25	Right No. 1 road wheel arm
C3	25	MB-2	25	Left No. 6 road wheel arm
E3	25	MB-2	25	Right No. 6 road wheel arm
C4	25	MB-2	25	Left No. 7 road wheel arm
E4	25	MB-2	25	Right No. 7 road wheel arm
B5	25	MB-2	25	Left tiedown point
F5	25	MB-2	25	Right tiedown point
C6	25	MB-2	25	Towing pintle
E6	25	MB-2	25	Towing pintle

* D-1 may be substituted for MB-2.

CHAPTER 5

HIGHWAY TRANSPORTABILITY GUIDANCE

Section I. GENERAL

5-1. Scope

This chapter provides transportability guidance for highway movement of the howitzers, M108, M109, and M109A1. It covers significant technical and physical characteristics and safety considerations and prescribes the manpower and materials required to prepare and load the howitzers on semitrailers.

5-2. Safety

In addition to safety precautions contained in chapter 3, CONUS movement is subject to all safety laws, rules, and regulations applicable to commercial carriers. In oversea areas movements are governed by theater regulations.

CAUTION

Do not allow howitzers to exceed 3 miles per hour during loading or unloading.

5-3. General

The howitzers are considered self-deliverable only under appropriate tactical situations. Although the vehicle tracks are equipped with rubber pads, movement over paved public highways will not be made without specific approval as outlined in AR 55-162. The weight of the howitzers is considered excessive for some bridges and will require special routing.

Section II. TRANSPORT BY SEMITRAILER

5-4. Preparation

a. Turret traverse and gun elevating mechanism must be in *travel* position, locked, and wire-tied to prevent rotation.

b. Remove all basic issue items from exterior of howitzer and secure inside of crew compartment.

5-5. Transport on Semitrailer

The howitzers, M108, M109, and M109A1, may be transported over highways loaded on semitrailers. Movement over public highways in CONUS and overseas should be made only when other modes of transport are not available. Highway shipments may be made using either military or commercial low-bed semitrailers of adequate capacity. Tractors and semitrailers large enough to transport the howitzers normally exceed length, width, and weight limitations in CONUS and overseas. Special permits are required in CONUS (AR 55-162), and special routing is required overseas for outsize/overweight shipments.

5-6. Transport on Semitrailer, M747

a. General. For purposes of illustration the howitzer, M109, is shown as a typical load on the semitrailer, M747 (fig 5-1).

b. Materials. Adequate tiedown chains and binders for securing the howitzer are carried aboard the trailer, M747, as basic issue items.

c. Loading.

WARNING

At no time during loading operations should personnel be on trailer bed.

WARNING

Loading should not be conducted on side or lateral slopes exceeding 10 percent or with a tractor-to-trailer offset angle greater than 5 degrees. Avoid loading on a severe downgrade to prevent the payload from rolling forward on the trailer.

(1) Position curbing assemblies on trailer bed so that they will be against inside edge of both tracks when howitzer is aboard trailer (item A, fig 5-1).

(2) Drive or winch howitzer to farthest forward position against wood bumpers (item B, fig 5-1). TM 9-2330-294-14 contains detailed instructions for winching operations.

(3) Place and wire-tie howitzer transmission in neutral position. Set parking brakes, if appropriate.

d. Tiedowns.

(1) Figure 5-1 provides a tiedown diagram that is compatible with standard loading practices and will adequately restrain the load against forces encountered at normal speeds and operating conditions.

(2) Attach chain (item C, fig 5-1) to left front tow shackle and pass through winch roller (item D, fig 5-1). Attach load binder to tiedown cleat on trailer gooseneck (item E, fig 5-1). Attach chain

to load binder and tighten. Repeat on right side. Attach chain to left rear tow shackle. Attach load binder to a tiedown fitting under the load and on opposite side of trailer. Attach chain to load binder and tighten. Repeat on right side. Rear tiedowns, properly applied, will provide restraint against lateral and rearward movement. Figure 5-2 provides a turning diagram of the semitrailer, M747, towed by truck-tractor, M123E2.

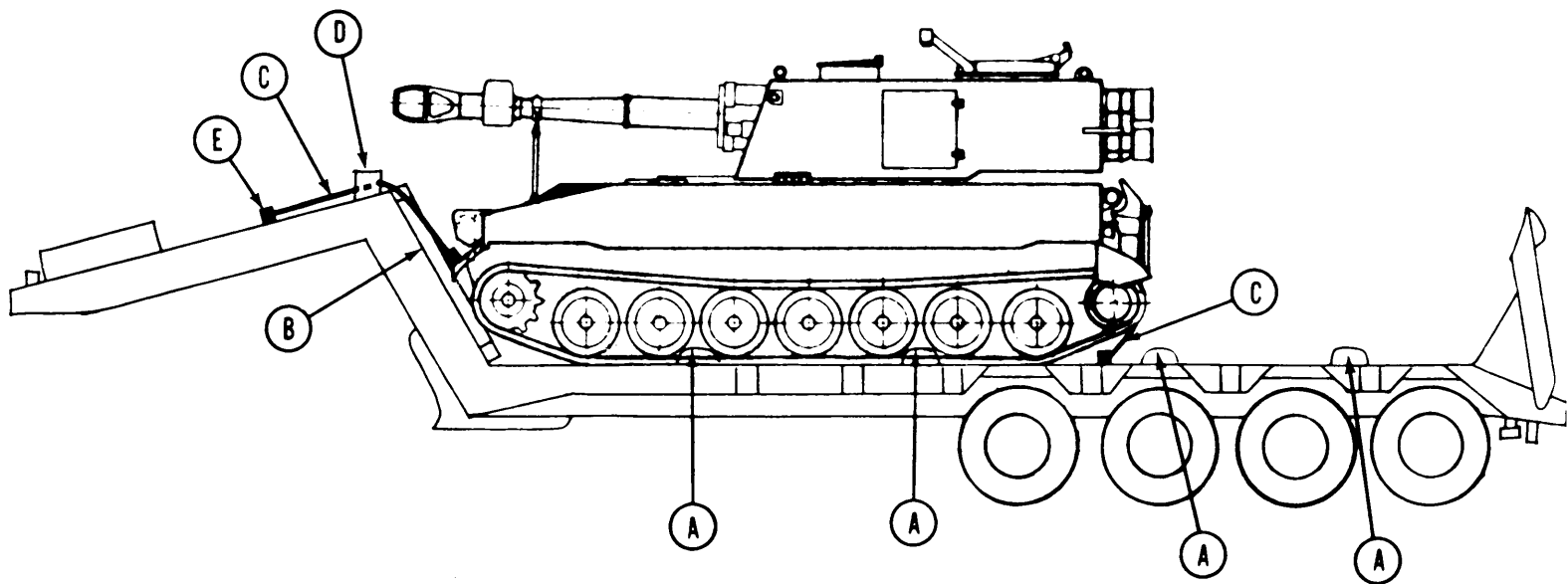
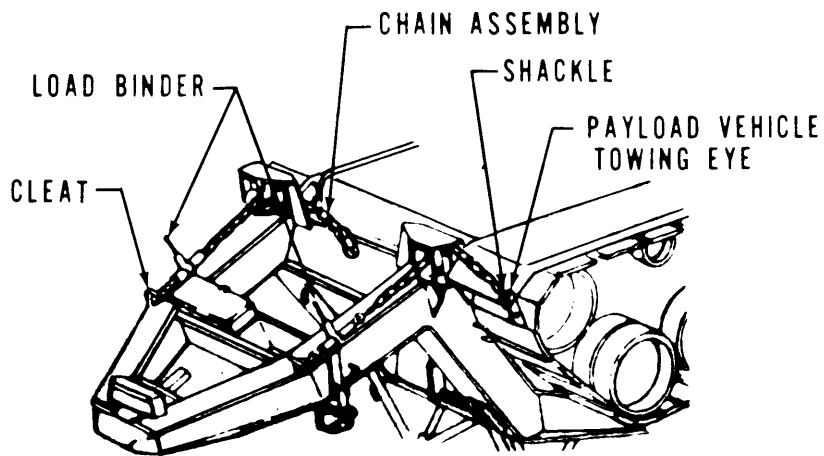
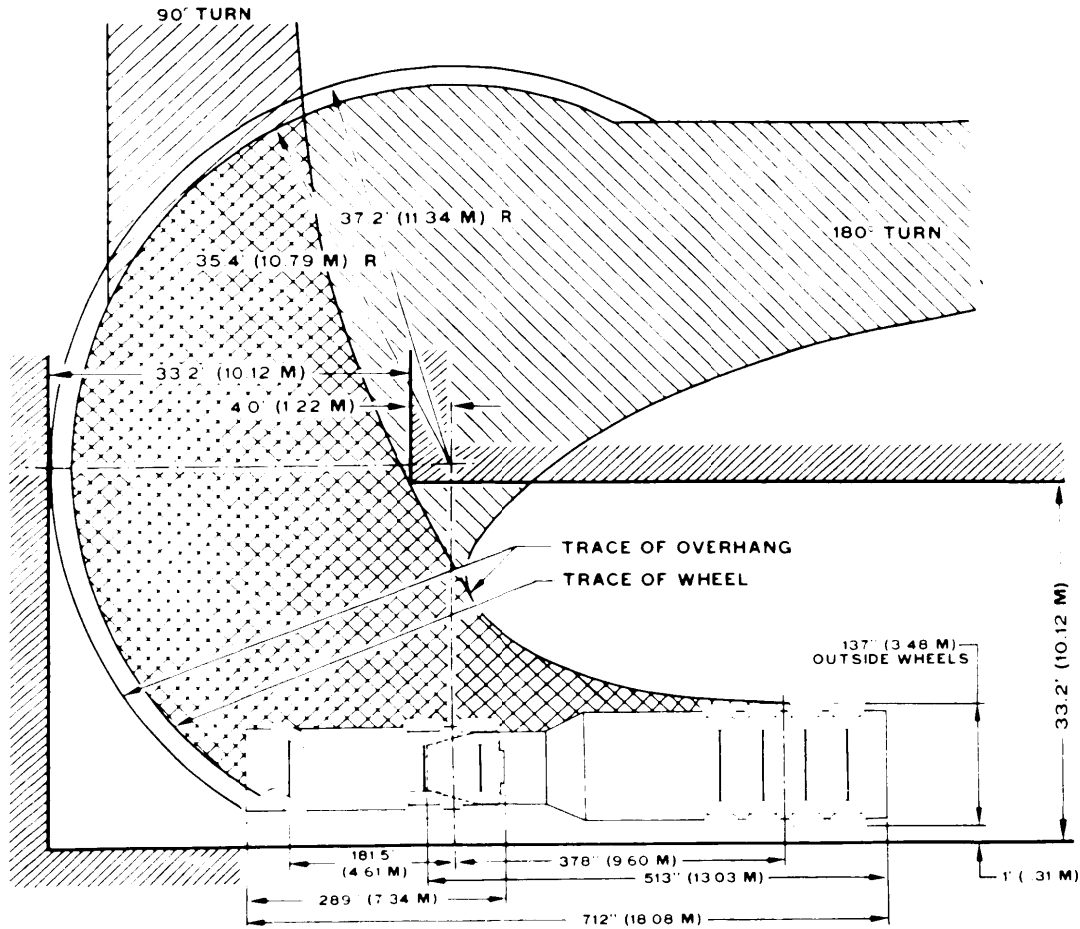





Figure 5-1. Blocking and tiedown diagram of typical howitzer, M109, on semitrailer, M747.



-  MIN PAVEMENT REQUIRED FOR 90° TURN
-  MIN PAVEMENT REQUIRED FOR 180° TURN
-  EXAMPLE OF CLEAR WIDTH NEEDED FOR 90° TURN

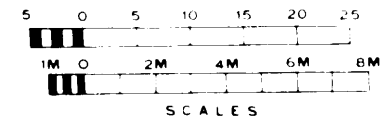

Figure 5-2. Turning diagram for M109 loaded on semitrailer, M747, towed by truck-tractor, M123E2.

CHAPTER 6

MARINE AND TERMINAL TRANSPORTABILITY GUIDANCE

Section I. GENERAL

6-1. Scope

This chapter provides transportability guidance for marine and terminal movement of the howitzers, M108, M109, and M109A1. It covers significant technical and physical characteristics and safety considerations and prescribes the materials and guidance required to prepare, lift, tie down, and discharge the howitzers.

6-2. Safety

In addition to the safety precautions contained in chapter 3, the following should be noted as applicable:

a. The activity offering the howitzer for transport will notify the carrier in the event ammunition or explosives are to be transported with the vehicle. Compliance with AR 55-228, paragraph 2-7 is mandatory.

b. Ammunition and vehicles will be handled and stowed in accordance with Water Carrier Tariff No. 27 or reissues thereof (app B).

c. Fire extinguishers must be available during all loading and unloading operations.

d. Vessel equipment and gear should be inspected before being used.

e. Stevedore slings and other items used in the loading and discharge operations should be inspected for condition and adequate capacity.

f. Personnel should be cautioned not to walk under vehicles being lifted.

g. Lifting eyes and shackles on each howitzer should be inspected to insure that they are complete and not damaged.

h. All lifts should have at least two tag lines attached to control the swing of the howitzer while suspended.

6-3. Water Shipment

The howitzers can be transported by a variety of inland-waterway cargo carriers and lighters and by most seagoing cargo vessels.

NOTE

The methods described in this chapter for lifting and securing howitzers are suggested procedures. Other methods of handling and stowage may be used provided they will insure safe delivery without damage.

Section II. LOADING AND SECURING

6-4. General Rules

a. Stowage. Whenever possible, howitzers should receive the protection of below-deck stowage. In general, good stowage of howitzers means having them placed as close together as practical, with minimum space between outer howitzer and sweatboards (approximately 4 to 6 inches); breakable parts protected; spare parts stowed in or near parent vehicle; brakes on with brake lever wire-tied; transmission in neutral with control lever wire-tied; battery terminals disconnected and taped; and fuel tanks drained. Secure by blocking tracks front and rear on both sides; lash with wire rope or chains to bulkhead, stanchions, or padeyes.

NOTE

1. When howitzers are loaded on vessels that are adequately ventilated by power blowers, such as roll-on/roll-off vessels, fuel need not be drained.

2. Tracked vehicles may arrive at the terminal with access hatches or turrets welded shut to prevent pilferage. Since these vehicles are not maneuverable under their own power, brakes are not set and transmissions are in the neutral position to permit towing in the loading area.

b. Lifting. Correct lifting points on the

howitzers, M108, M109, and M109A1, are the lifting eyes located one on each upper front corner of hull and one on each upper rear corner, for a total of four. For typical lifting diagram see figure 6-1.

CAUTION

The lifting eyes located on the top front and rear corners of the turret are for lifting *only the turret* and not the entire howitzer.

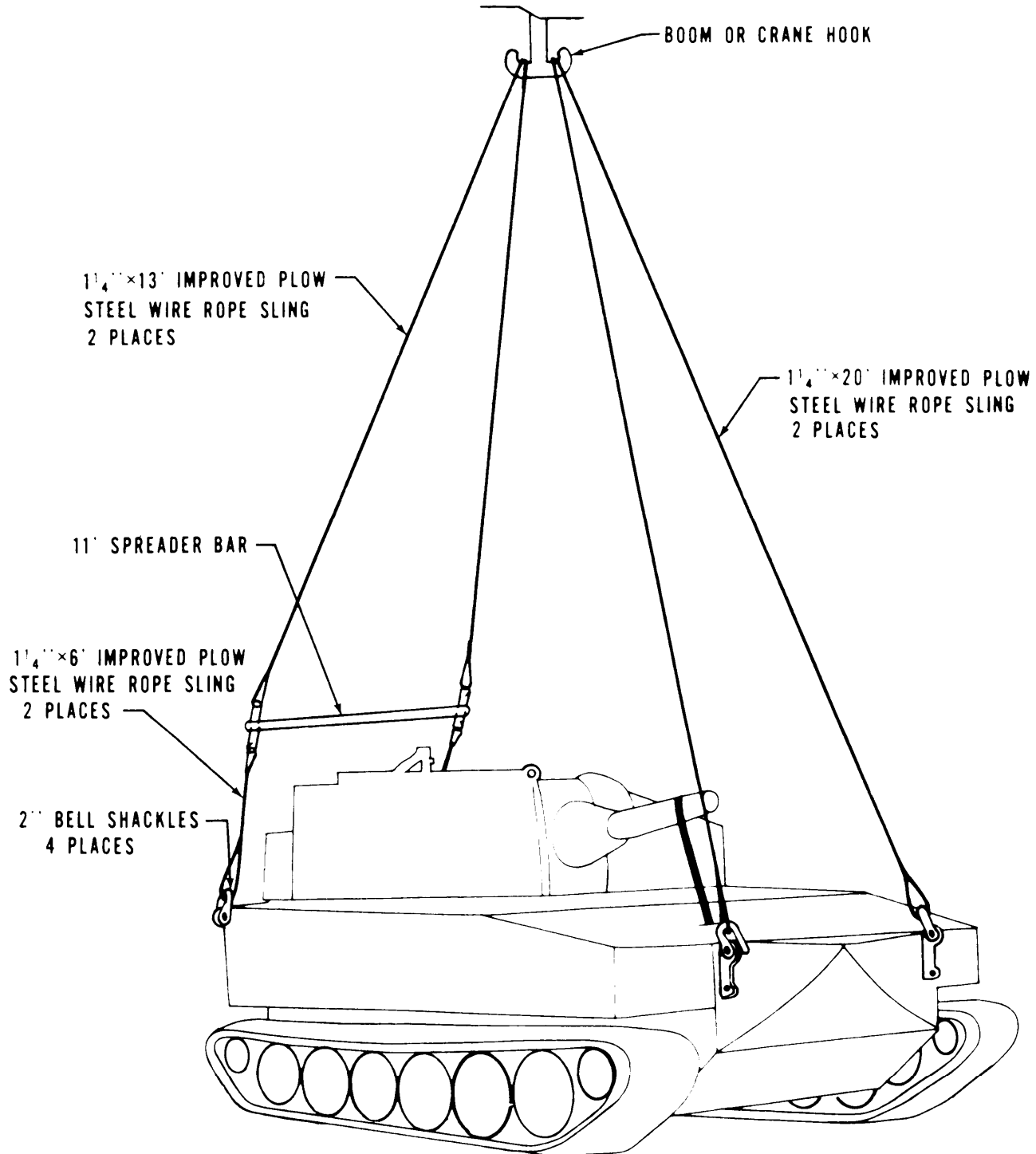

Figure 6-1. Lifting diagram for M108 using four-legged bridge sling and one spreader bar.

c. Loading. Howitzers will be loaded on vessels in their minimum configuration as described in paragraph 2-5. They may be loaded aboard landing craft, beach discharge lighters, heavy amphibious lighters, and landing ships under their own power or by crane of adequate capacity. The howitzers can also be loaded under their own power onto the deck of barges from a pier when tidal conditions are suitable and ramps are

available. They can be loaded onto seagoing vessels by shoreside or floating cranes of adequate capacity or by heavy-lift ships' gear. The howitzers can, under their own power or towed, be loaded on roll-on/roll-off vessels. Figure 6-2 shows typical blocking and tiedown details. Tables 6-1 and 6-2 list materials and their application.

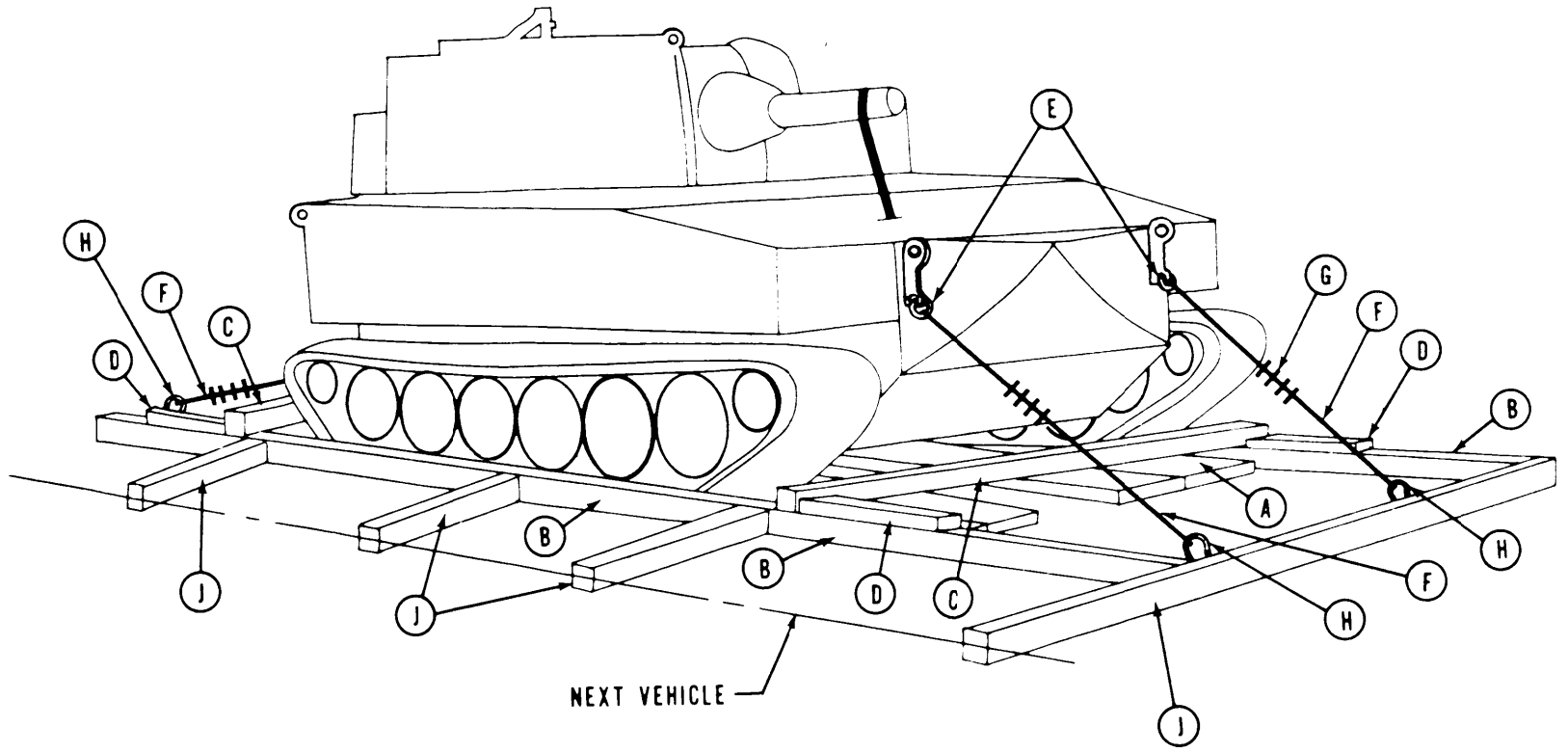

Figure 6-2. Typical blocking and tiedown of howitzer, M108, in general cargo vessel.

d. *Special Design.* Seatrains ships, roll-on/roll-off ships, landing ships, and attack cargo ships are equipped with patented lashing gear and pre-positioned fittings in the decks. The use of such equipment is adequate, and additional blocking and bracing is not required.

6-5. Barges and Lighters

When transporting the howitzers by barge or similar lighterage to or from vessels secured to piers or at a sheltered anchorage, blocking and chocking will be required. When moving extended distances or through rough waters, tiedowns must also be used.

6-6. Landing Ships, Landing Craft, and Amphibians

When transporting the howitzers for extended

distances or through rough waters, blocking and tiedowns must be used. In most cases the vessels are equipped with turnbuckles with a sheep's foot fitting on one end that fits into a deck cloverleaf. Where not provided, a suitable substitute may be used.

6-7. Barge-Type Ships (LASH) (SEABEE)

a. *General.* For transporting the howitzer by barge-type ships, securement is illustrated in figures 6-3 and 6-4. Barge stability is noticeably affected by the loading of heavy-lift items, and tracked vehicles should be loaded symmetrically in sequence about the center line of the barge or lighter. **The howitzers should be loaded in a manner to counterbalance variations in centers of gravity; that is, alternate head to tail.**

Table 6-1. Bill of Materials for Blocking and Tiedown of Typical Howitzer, M108, in General Cargo Vessel (Fig 6-2)

Item	Description	Approximate quantity
Lumber	Douglas-fir, or comparable lumber, straight-grain, free from material defects: Fed Spec MM-L-751H: 4- x 6-in. 2- x 12-in. 6- x 8-in.	5 linear ft 60 linear ft 100 linear ft
Nails	Common, steel; flat head; bright or cement-coated; table XI-b, Fed Spec FF-N-105B: 40d	120
Wire rope	6 x 19, IWRC; improved plow steel; preformed, regular-lay; table X, Fed Spec RR-W-410C: 5/8-in.	60 ft
Shackles	Wire rope, "U"-bolt clips, saddled, single grip, steel, Crosby heavy-duty, or equal; MIL-STD 16842: 5/8-in. Clevis assembly, suspension, bolt and nut type, large, NSN 1670-00-090-5354, or equal (For front and rear towing and tiedown provisions).	16 4

Table 6-2. Application of Materials for Blocking and Tiedown of Typical M108 in General Cargo Vessel (Fig 6-2)

Item	No. Required	Application
A	4	Lumber, 2- x 12- x 168-in. Pre-position on vessel hold deck so that two pieces will be under each howitzer track.
B	2	Side blocking. Each consists of 6- x 8- x 288-in. lumber. Locate one piece on each side of howitzer against outside edge of tracks.
C	2	End blocking. Each consists of 6- x 8- x 140-in. lumber. Locate on top of item B and against tracks front and rear. Toenail to item B with four 40d nails at each end.
D	4	Backup cleats. Each consists of 4- x 6- x 12-in. lumber. Locate on top of item B against item C. Nail to item B with four 40d nails.
E	4	Shackles. Secure one shackle to each towing lug (two at front and two at rear of howitzer).
F	4	Wire rope, 15 ft. Make a complete loop through shackle and padeye, secure with clamps (item G).
G	16	Clamps, 5/8-in. Use four to secure each item F.
H	4	Padeyes, built into vessel deck.
J	as required	Bracing. Each consists of 6- x 8-in., by length-to-suit. Brace as required against adjacent vehicle, cargo, or side of vessel bulkhead. Secure each end of each piece to adjacent blocking or bracing by toenailing with four 40d nails.

b. Dunnage. Dunnage is not generally used beneath the tracks of vehicles equipped with rubber track pads. Frictional forces between the pads and deck are sufficient to make it unnecessary. However, deck surfaces should be dry and free from grease or debris.

c. Blocking. Howitzers may be adequately blocked and braced with 6- x 8-inch timbers. Blocking should be installed as a separator between the howitzer track and barge bulkhead.

Blocking is normally installed in front and rear of tracks and the bracing part force-fitted to the bulkhead. Loading, blocking, and bracing proceed from the outer areas of the barge toward the center, which is loaded last. Separator timbers are installed against the bulkhead or track and the next howitzer loaded is placed firmly against the timber. Any void area remaining in the center of the barge after the last vehicle is loaded is filled by cut and force-fitted blocking.

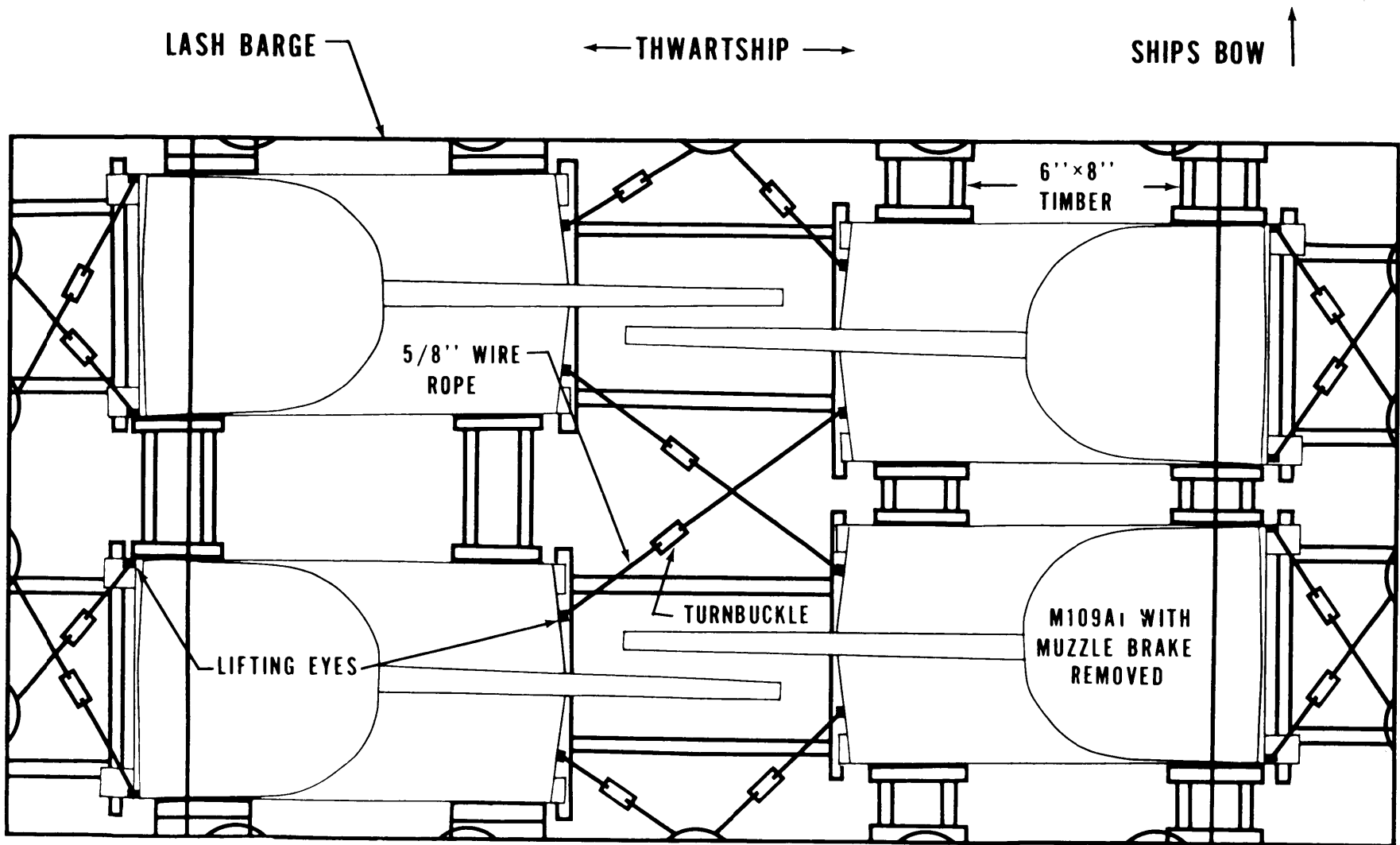

Figure 6-3. Loading of four howitzers, M109A1, on LASH barge, using wire rope, cable clamps, and turnbuckles, with blocking between howitzers and howitzers to hull.

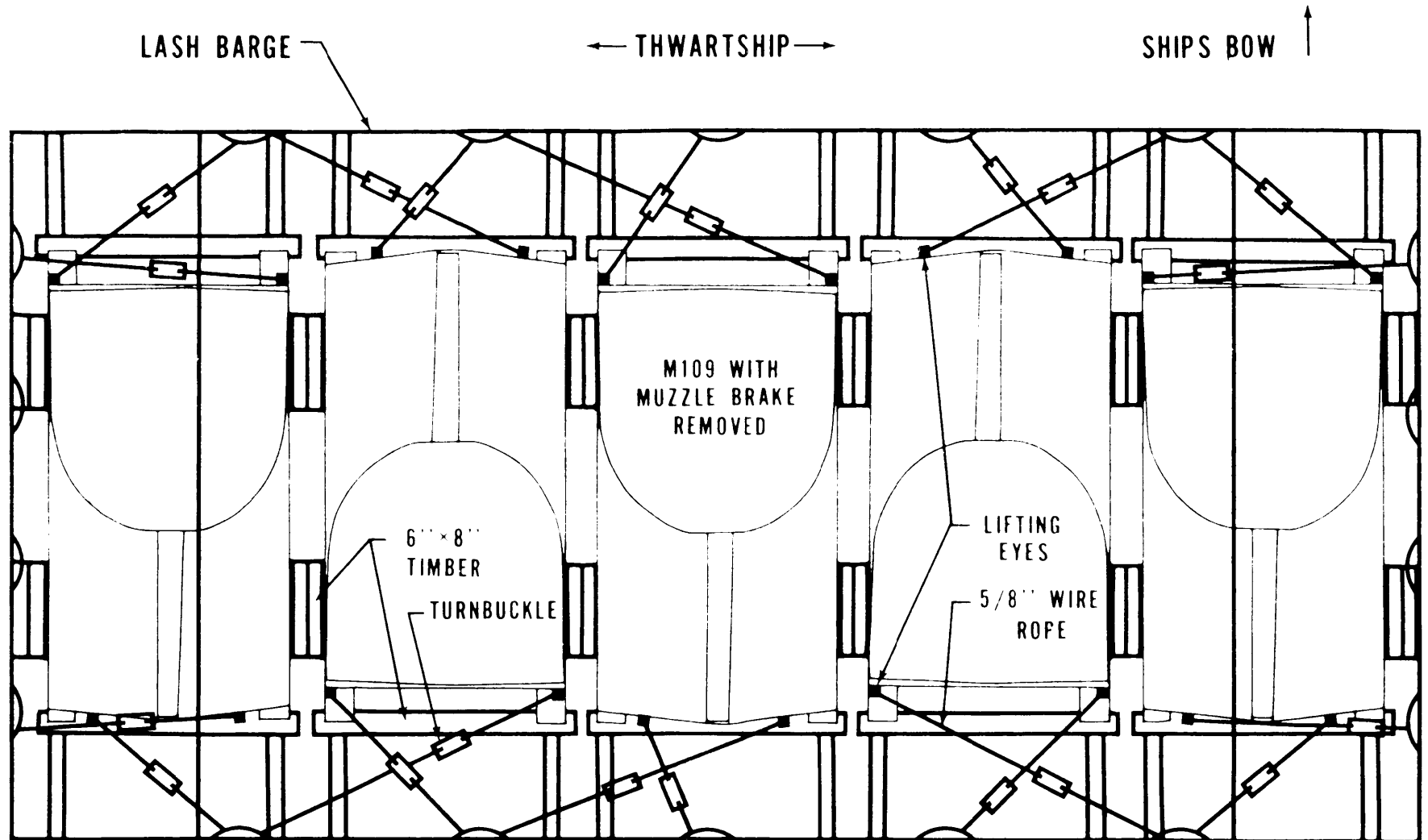

Figure 6-4. Loading of five howitzers, M109, on LASH barge, using wire rope, cable clamps, and turnbuckles, with blocking between howitzers and howitzers to hull.

CHAPTER 7

RAIL TRANSPORTABILITY GUIDANCE

Section I. GENERAL

7-1. Scope

This chapter provides transportability guidance for rail movement of the howitzers, M108, M109, and M109A1. It covers significant technical and physical characteristics, safety considerations, and prescribes the materials and guidance required to prepare, load, and tie down the howitzers on open top flatcars.

7-2. Maximum Utilization of Railcars

Additional cargo, as approved by the activity offering the howitzers for transport, may be transported with the howitzers.

Section II. TRANSPORT ON CONUS RAILWAYS

7-3. General

The transportability guidance contained in this section is applicable when the howitzers are transported on CONUS railways. Consideration is given to single and multiple movements on the types of railcars normally used for the transport of this type of equipment. When reduced to the minimum width of 124 inches, the howitzer can be transported without restriction and without sectionalization or major disassembly.

7-4. Preparation

The degrees of preparation of the howitzers for transport is dependent upon the operational commitment.

7-5. Loading on General-Purpose Flatcars

a. The howitzers may be placed in the tiedown position on a railcar by a crane, or they may be driven or towed onto the railcar provided a suitable ramp or bridge is available.

CAUTION

Do not allow howitzer to exceed 3 miles per hour during loading or unloading operations.

b. The load shown in figures 7-1 and 7-2 is based on flatcar width of 10 feet 6 inches. Figure 7-3 provides detailed instructions for blocking and tie down. Table 7-1 provides a bill of materials

and table 7-2 presents application of those materials for securing howitzers on general-purpose flatcars.

NOTE

A staggered nailing pattern should be used when lumber or laminated lumber is nailed to the floor of the railcar. The nailing pattern for an upper piece of lumber will be adjusted as required so that a nail for that piece will not be driven into or right beside a nail in the lower piece of lumber.

7-6. Loading on Special-Purpose Flatcars

a. The load shown in figures 7-4 and 7-5 is based on the use of a CONUS HTTX or similar types of flatcars. This car is equipped with special heavy-duty tiedown anchors and chain assemblies contained in channels along each side of the car and on each side of the center sill. Table 7-3 provides a bill of materials, and table 7-4 presents application of those materials for securing howitzers on HTTX flatcars.

b. The special-purpose cushion rub-rail flatcar is not adequate for transporting the howitzer, M108, M109, and M109A1. The weight of each of the howitzers exceeds the load restraint capability of the tiedown chains and rub-rail.

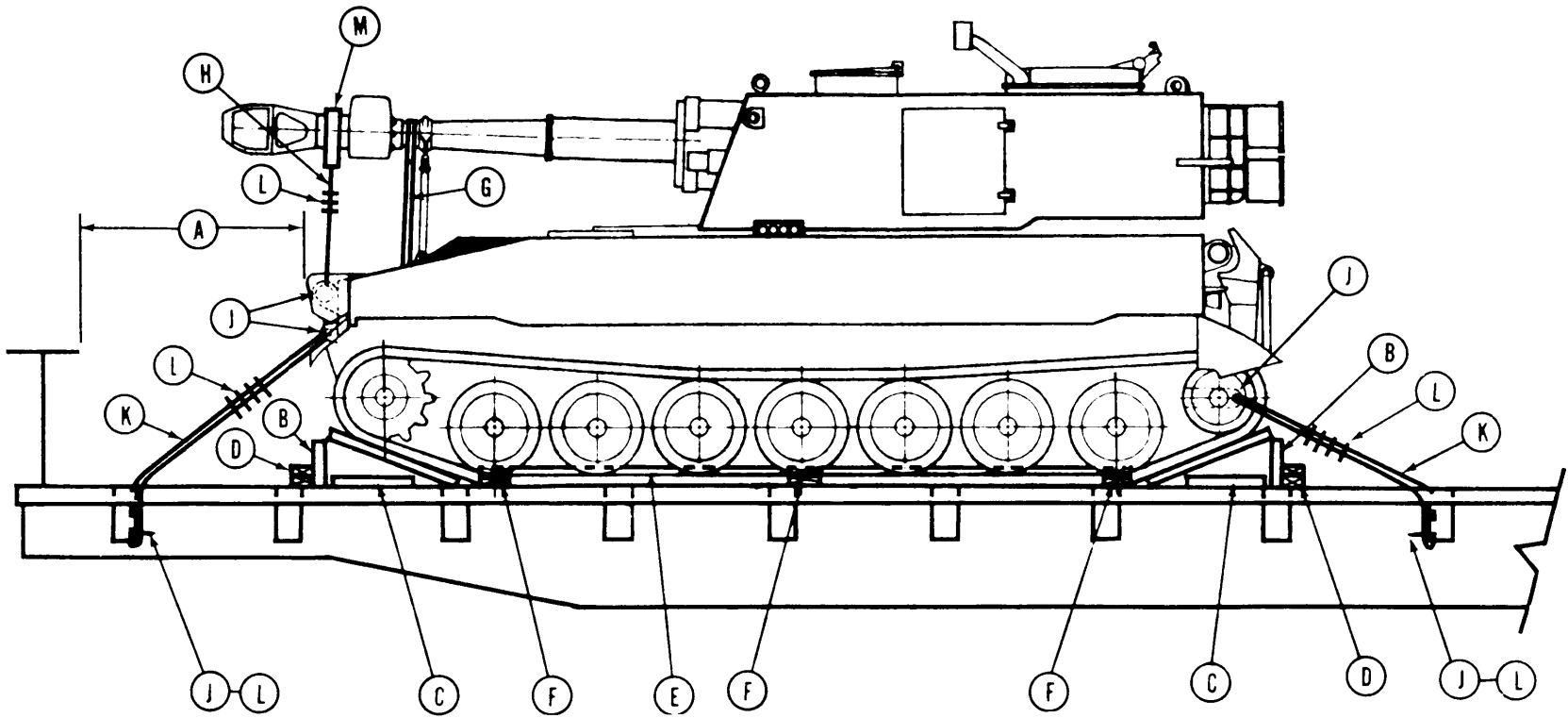

Figure 7-1. Blocking and tiedown diagram of typical howitzer, M109, on CONUS general-purpose flatcar (side view).

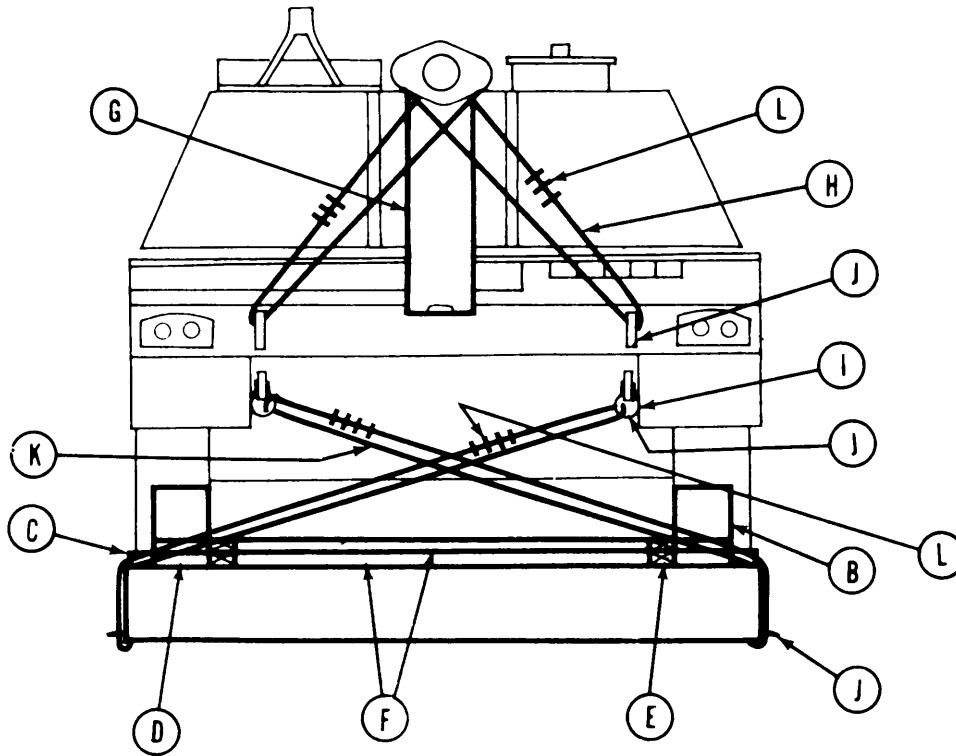
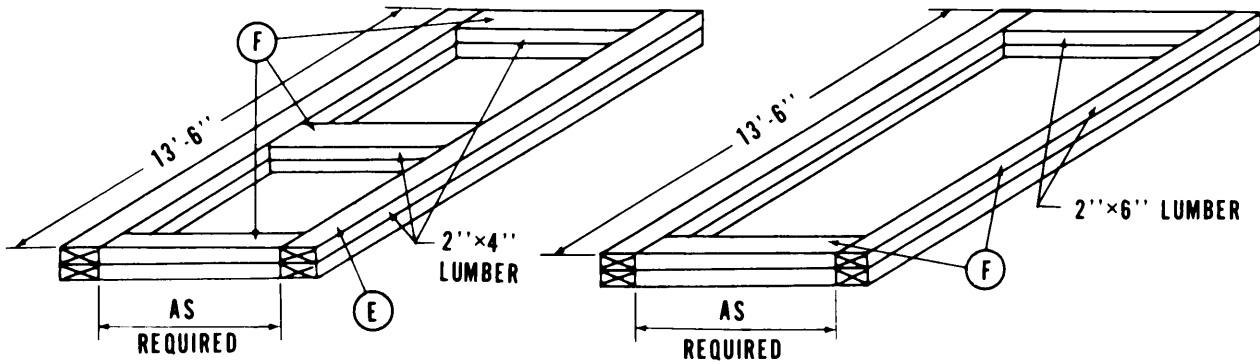
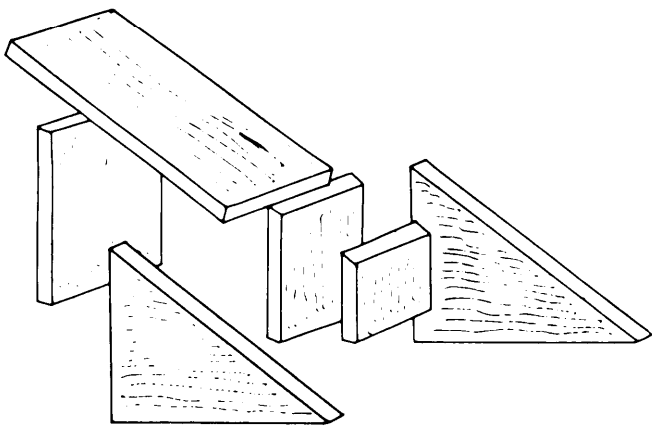

Figure 7-2. Blocking and tiedown diagram of typical howitzer, M109, on CONUS general-purpose flatcar (end view).



DETAIL 1

DETAIL 2



EXPLODED VIEW

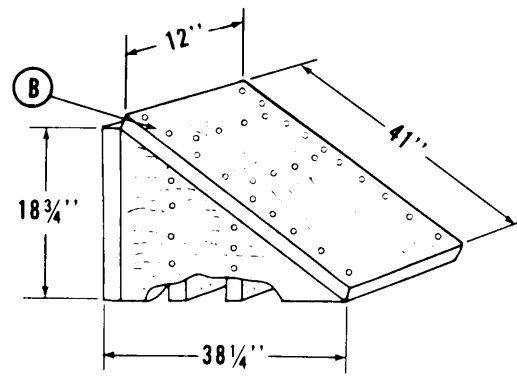

ASSEMBLED VIEW

DETAIL 3

FABRICATE BLOCKS FROM 2- \times 12-IN LUMBER.
USE 20d NAILS.

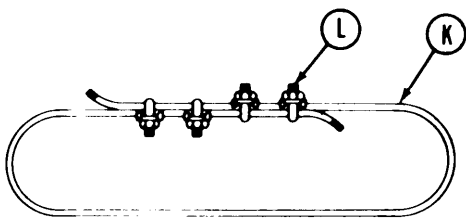

DETAIL 4

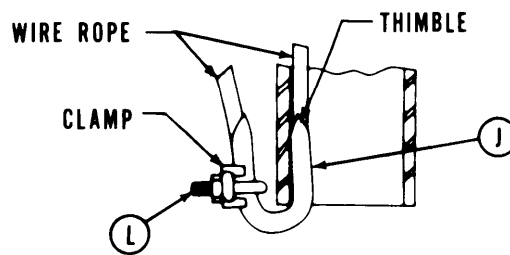

DETAIL 5

Figure 7-3. Blocking and tiedown detail diagram.

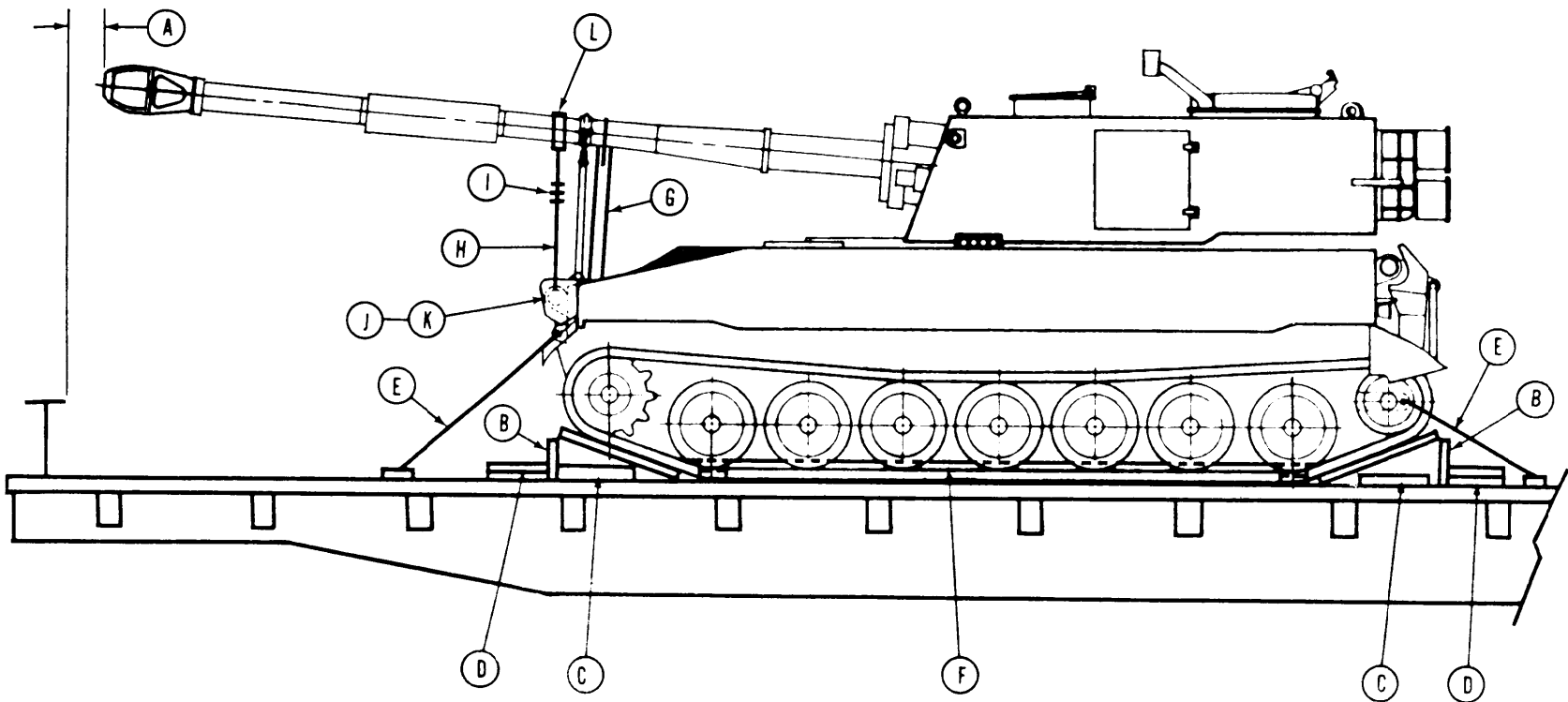

Figure 7-1. Blocking and tiedown diagram of typical howitzer, M109A1, on CONUS HTTX or similar types of flatcars (side view).

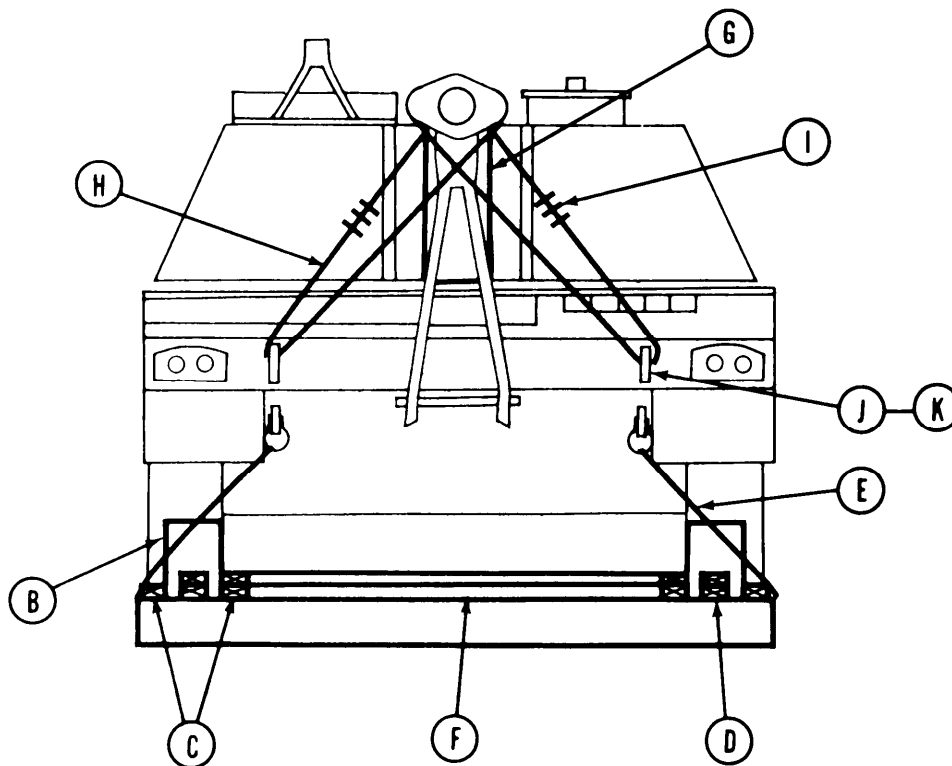

Figure 7-5. Blocking and tiedown diagram of typical howitzer, M109A1, on CONUS HTTX or similar types of flatcars (end view).

Table 7-1. Bill of Materials for Blocking and Tiedown of Typical Howitzer, M109, on CONUS General-Purpose Flatcar (Fig 7-1, 7-2, and 7-3)

Item	Description	Approximate quantity
Lumber	Douglas-fir. or comparable lumber, straight-grain, free from material defects; Fed Spec MM-L-751H: 2- x 4-in. 2- x 6-in. 2- x 12-in.	125 linear ft 5 linear ft 65 linear ft
Nails	Common, steel; flathead; bright or cement-coated; table XI-b, Fed Spec FF-N-105B: 30d 20d 6d	200 240 4
Thimbles	Standard, open-type: 3/8-in. 5/8-in.	2 16
Clamps	Wire rope, "U"-bolt clips, saddled, single grip, steel, Crosby heavy-duty, or equal; MIL-STD 16842: 3/8-in. 5/8-in.	8 32
Cushioning material	3/4-in. rubber hose (substitute if desired, waterproof paper, burlap, or other suitable material, which will prevent wire rope from damaging gun barrel).	8 ft
Steel strapping Shackles	3/4-in., high-tension. Clevis assembly, suspension, bolt and nut type, large, NSN 1670-00-090-5354.	3 linear ft 4
Wire rope	6 x 19, IWRC; improved plow steel: preformed, regular-lay; table X, Fed Spec RR-W-410C: 3/8-in. 5/8-in.	30 ft 175 ft

Table 7-2. Application of Materials for Blocking and Tiedown of Typical Howitzer, M109, on CONUS General-Purpose Flatcar (Fig. 7-1, 7-2, and 7-3)

Item	No. Required	Application
A	—	Brake-wheel clearance. Minimum clearance required is 6 in. above, in back of, and on both sides of, and 4 in. underneath wheel (fig 7-1).
B	4	Blocks (detail 3, fig 7-3). Locate one against the front and rear of each track.
C	8	Side cleat. Each to consist of one piece of 2- x 4- x 20-in. lumber. Locate one piece on each side of each item B. Secure to car floor with six 30d nails.
D	4	End cleat. Each to consist of two pieces of 2- x 4- x 12-in. lumber. Locate against ends of item B. Secure lower piece to car floor with four 30d nails and top piece to lower piece with four 30d nails.
E	2	Frame. Each to consist of two pieces of 2- x 4-in. x 13-ft 6-in. lumber. Locate on car floor against inside edge of each track, and secure lower piece to floor with twelve 30d nails and top piece to lower piece with twelve 30d nails (detail 1, fig 7-3).
F	3	Frame. Each to consist of two pieces of 2- x 4-in. lumber long enough to fill space between items E (approximately 86 in.). Locate one near center and one at each end between items E. Secure lower piece to car floor with four 30d nails and top piece to lower piece with four 30d nails (detail 1, fig 7-3).
G	1	Brace. To consist of one piece of 2- x 6-in. lumber, with length as required. Apply to vehicle hull under gun barrel. Place one piece of 3/4-in. high-tension band over gun barrel, and secure to each side of brace with two 6d nails.
H	2	Wire rope. Each to consist of one piece 3/8-in. wire rope, with length as required (approximately 15 ft). Wrap gun barrel with cushioning material. Apply wire rope in a complete loop around gun to front lifting eyes, and secure with three 3/8-in. clamps, item L.
I	4	Shackle. Secure one shackle to each towing lug (two at front and two at rear of vehicle).
J	18	Thimble. Locate two 5/8-in. thimbles on items K at each item I and stake pocket (detail 5, fig 7-3). Locate one 3/8-in. thimble on each item H at lifting eye.
K	4	Wire rope. Each consists of one piece of 5/8-in. wire rope doubled and attached through each item I and appropriate stake pocket.
L	40	Clamp. Secure each item H with three 3/8-in. clamps. Secure each item K with four 5/8-in. clamps (detail 4, fig 7-3). Secure each item J with either a 3/8-in. or 5/8-in. clamp, as appropriate.
M	2	Padding. Each to consist of one piece of 3/4-in. x 4-ft rubber hose. Thread each item H through hose so that hose is between gun barrel and item H. Substitute, if desired, waterproof paper, burlap, or other suitable material that will prevent wire rope from damaging gun barrel.

GENERAL INSTRUCTIONS

1. The turret gun is to be secured in the gun travel lock. The turret lock and elevating mechanism hand wheels must be locked and wired to prevent rotation.
2. Hand brakes must not be set.
3. Tensioning of wire rope can be accomplished with an applicable sized come-along mechanical hoist or equal tensioning device. Do not overtension wire rope around gun barrel.
4. Loading rules 3, 4, 5, 7, 9, 10, 14, 15, 19, and 19-A, Section I, *Association of American Railroads Rules Governing the Loading of Commodities on Open Top Cars and Trailers* provide applicable guidance and are mandatory in application.

Table 7-3. Bill of Materials for Blocking and Tiedown of Typical Howitzer, M109A1, on CONUS HTTX or Similar Types of Flatcars (Fig 7-3, 7-4, and 7-5).

Item	Description	Approximate quantity
Lumber	Douglas-fir or comparable lumber straight-grain, free from material defects; Fed Spec MM-L-751H: 2- x 4-in. 2- x 6-in. 2- x 12-in.	30 linear ft 90 linear ft 65 linear ft
Nails	Common, steel; flathead; bright or cement-coated; table XI-b, Fed Spec FF-N-105B: 30d 20d 6d	200 240 4
Thimbles	Standard, open-type: 3/8-in.	2
Clamps	Wire rope, "U"-bolt clips, saddled, single grip, steel, Crosby heavy-duty, or equal; MIL-STD 16842: 3/8-in.	8
Cushioning material	3/4-in. rubber hose (substitute, if desired, waterproof paper, burlap, or other suitable material that will prevent wire rope from damaging gun barrel).	8 ft
Steel strapping	3/4-in., high-tension.	4 ft
Shackles	Clevis assembly, suspension, bolt and nut type, large, NSN 1670-00-090-5354.	4
Wire rope	6 x 19, IWRC: improved plow steel; preformed, regular-lay; table X, Fed Spec RR-W-410C: 3/8-in.	30 ft

Table 7-4. Application of Materials for Blocking and Tiedown of Typical Howitzer, M109A1, on CONUS HTTX or Similar Types of Flatcars (Fig 7-3, 7-4, and 7-5).

Item	No. Required	Application
A	—	Brake-wheel clearance. Minimum clearance required is 6 in. above, in back of, and on both sides of and 4 in. underneath wheel (fig 7-4).
B	4	Blocks (detail 3, fig 7-3). Locate one against the front and rear of each track.
C	8	Side cleat. Each consists of one piece of 2- x 4- x 20-in. lumber. Locate one on each side of each item B, and secure to car floor with six 30d nails.
D	4	End cleat. Each consists of two pieces of 2- x 4- x 18-in. lumber. Locate against ends of item B. Secure lower piece to car floor with four 30d nails and top piece to lower piece with four 30d nails.
E	4	Chain, 1/2-in. alloy proof-tested to 27,500 lb (provided with railcar). Secure chains to tiedown shackles on front and rear of vehicle (fig 7-5). After chains are tightened, hit sharply with a hammer to relieve any binding. Retighten if necessary. There must be at least one full wrap of chain around the tensioning device drum. If turnbuckles are used as a tensioning device they must be equipped with locknuts to prevent loosening.
F	1	Frame. Frame work to consist of 2- x 6-in. lumber (detail 2, fig 7-3). Locate one piece of 2- x 6-in. x 13-ft 6-in. lumber on car floor against inside edge of each track, and secure each piece with twelve 30d nails. Secure upper pieces to each lower piece with twelve 30d nails. Nails should be applied in a staggered pattern. Four pieces of 2- x 6-in. lumber cut to fit shall be placed between the longitudinal pieces. Secure each lower piece to car floor with four 30d nails. Secure top pieces to lower pieces each with four 30d nails.
G	1	Brace. To consist of one piece of 2- x 6-in. lumber length, as required. Apply to vehicle hull under gun barrel, and secure with one piece of 3/4-in. high-tension band over gun barrel secured to each side of brace with two 6d nails.
H	2	Wire rope. Each consist of one piece of 3/8-in. wire rope, length as required (approximately 15 ft). Apply wire rope in a complete loop around gun to front lifting eyes, and secure with three 3/8-in. clamps, item 1.
I	6	Clamp. Secure each item H with three 3/8-in. clamps. Secure each item K with one 3/8-in. clamp.

Table 7-4 – Continued

Item	No. Required	Application
J	2	Clamp. Secure each item K to each item H at front lifting eyes (detail 5, fig 7-3). Thimble. 3/8-in. thimble attached to each item H (detail 5, fig 7-3). Padding. Each to consist of one piece of 3/8-in. x 4-ft rubber hose. Thread each item H through hose so that hose is between gun barrel and item H. Substitute, if desired, waterproof paper, burlap, or other suitable material that will prevent wire rope from damaging gun barrel.
K	2	
L	2	

GENERAL INSTRUCTIONS

1. The turret gun is to be secured in the gun travel lock. The turret lock and elevating mechanism hand wheels must be locked and wired to prevent rotation.
2. Hand brakes must not be set.
3. Tensioning of wire rope can be accomplished with an applicable sized come-along mechanical hoist, or equal tensioning device. Do not overtension wire rope around gun barrel.
4. Loading Rules 1, 2, 3, 4, 5, 7, 9, 14, 15, and 19-A, Section I, *Association of American Railroads Rules Governing the Loading of Commodities on Open Top Cars and Trailers* provide applicable guidance and are mandatory in application.

Section III. TRANSPORT ON FOREIGN RAILWAYS

7-7. General

The transportability guidance contained in this section is applicable when the howitzers are transported on foreign railways. Consideration is given to single and multiple movements on the types of railcars normally used for the transport of this type of equipment. The howitzers can be transported in their reduced height and width configurations with restrictions within European countries complying with the International Loading Gauge (formerly Berne International); the majority of the countries in the Middle East; and South America, Australia, India, and Pakistan. In the Middle East and South America the clearances vary by country, and each country will require a separate check. In Australia, India, and Pakistan, wide or broad-gauge railways provide greater clearances and less restrictions. Because of the various designation systems used by different countries, foreign railcars are difficult

to classify. In addition, clearances vary between countries and within a country; consequently, evaluation of transportability capability must be made on an individual basis.

7-8. Transport on US Army-Owned Foreign Service Flatcars

a. The howitzers can be transported on a number of US Army-owned foreign service flatcars. These flatcars are exclusively for the transport of US military material. Table 7-5 presents a few of the flatcars available in Europe that are suitable for transporting the howitzers.

b. The materials required for blocking and tiedown of the howitzers on US Army-owned foreign service flatcars are essentially the same as those used for transporting the howitzer within CONUS. For general guidance, refer to figures 7-1, 7-2, 7-3 and tables 7-1 and 7-2.

Table 7-5. Characteristics of US Army-Owned European Flatcars Available for Transporting Vehicles

Flatcar designation	Capacity		Width	Platform height*
SSY**	52-ton (47.17 MTON)	31-ft. 2-in. (9.50 m)	10-ft. 4-in. (3.15 m)	4-ft. 2¾-in. (1.29 m)
SSYS	66-ton (59.88 MTON)	31-ft. 2-in. (9.50 m)	10-ft. 4-in. (3.15 m)	4- ft. 2¾-in. (1.29 m)
FFLM	90-ton (81.65 MTON)	46-ft. 8-in. (14.42 m)	10-ft. 3-in. (3.12 m)	4- ft. 2¾-in. (1.29 m)

* Above top of rail.

** German owned SSY cars are designated RLMMP.

APPENDIX A

CONVERSION TABLES

1. Common Metric Abbreviations.

m = meter
 dm = decimeter
 cm = centimeter
 mm = millimeter

kg = kilogram
 km = kilometer
 MT = metric ton

2. Linear Measure.

1 mi = 1,609.35 m
 1 yd = 0.9144 m
 1 ft = 0.3048 m
 1 in. = 0.0254 m
 1 m = 10 dm = 100 cm = 1000 mm

1 km = 0.6214 mi
 1 m = 1.0936 yd
 1 m = 3.2808 ft
 1 m = 39.3700 in.

3. Surface Measure.

1 sq yd = 0.8361 sq m
 1 sq ft = 0.0929 sq m
 1 sq in. = 0.00065 sq m

1 sq m = 1.196 sq yd
 1 sq m = 10.764 sq ft
 1 sq m = 1,550 sq in.

4. Cubic Measure.

1 cu yd = 0.76455 cu m
 1 cu ft = 0.02831 cu m
 1 cu in. = 0.000016 cu m

1 cu m = 1.31 cu yd
 1 cu m = 35.30 cu ft
 1 cu m = 61,023 cu in.

5. Weight.

1 STON = 907.185 kg
 1 lb = 0.45359 kg

1 kg = 2.2046 lb
 1 MT = 1,000 kg
 1 MT = 2,204.62 lb

6. The following simplified conversion factors are accurate to within 2 percent for quick computations:

a. Inches to centimeters — Multiply in. by 10 and divide by 4.

b. Yards to meters — Multiply yd by 9 and divide by 10.

c. Miles to kilometers — Multiply mi by 8 and divide by 5.

d. Pounds to kilograms - Multiply lb by 5 and divide by 11.

Paragraph 7-37, FM 55-15 and paragraph 2-15, TM 55-450-15 contain additional detailed conversion factors.

7. The following conversions are provided for guidance when procuring lumber, wire rope, or wire in areas that use the metric system. Lumber sizes are rounded off to nearest $\frac{1}{2}$ cm.

a. Lumber.

2-in. x 4-in. x desired length = 5-cm x 10-cm x desired length

1-in. x 6-in. x desired length = 2.5-cm x 15-cm x desired length

6-in. x 8-in. x desired length = 15-cm x 20-cm x desired length

1-in. x 12-in. x desired length = 2.5-cm x 30-cm x desired length (length normally expressed in ft or m.)

b. Wire rope.

3/8-in. dia = 9.5-mm dia

1/2-in. dia = 12.7-mm dia

5/8-in. dia = 15.8-mm dia

3/4-in. dia = 19.0-mm dia

7/8-in. dia = 22.2-mm dia

1-in. dia = 25.4-mm dia

1 1/4-in. dia = 31.7-mm dia

1 1/2-in. dia = 38.1-mm dia

Round off to next higher whole mm of available wire rope sizes.

c. Wire. No. 8 gauge annealed (11/64-in. dia) = 4-37-mm dia. Round off as in *b* above.

APPENDIX B

REFERENCES

1. Army Regulations (AR)

55-29	Military Convoy Operations in CONUS.
55-162	Permits for Oversize, Overweight, or Other Special Military Movements on Public Highways in the Contiguous States and the District of Columbia.
55-228	Transportation by Water of Explosives and Hazardous Cargo.
55-355	Military Traffic Management Regulation.
70-39	Criteria for Air Transport and Airdrop of Material.
385-40	Accident Reporting and Records.
746-1	Color, Marking, and Preparation of Equipment for Shipment.

2. Field Manuals (FM)

1-100	Army Aviation Utilization.
5-36	Route Reconnaissance and Classification.
55-13	Air Transport of Supplies and Equipment: Standard Loads in Air Force C-5 Aircraft.
55-15	Transportation Reference Data.

3. Supply Bulletins (SB)

700-20	Army Adopted Items of Material.
--------	---------------------------------

4. Technical Bulletins (TB)

55-46-1	Standard Characteristics (Dimensions, Weight, and Cube) for Transportability of Military Vehicles and Equipment.
---------	--

5. Technical Manuals (TM)

5-725	Rigging.
9-2330-294-14	Operation, Organizational, DS/GS Maintenance Manual for Semitrailer, Low Bed, Heavy Equipment Transporter, 52½-Ton, XM747.
9-2350-217-10	Operators Manual: Howitzer, Light, Self-Propelled, 105 MM, M108 (2350-00-440-8810); Howitzer, Medium, Self-Propelled, 155MM, M109, (2350-00-440-8811); Howitzer, Medium, Self-Propelled, 155 MM, M109A1 (2350-00-485-9662)
38-250-(AFM 71-4)	Packaging and Handling of Dangerous Materials for Transport on Military Aircraft
55-405-9	Weight and Balance
55-450-15	Air Movement of Troops and Equipment (Non-Tactical)
55-500	Marine Equipment Characteristics and Data
55-513	Military Stevedoring

6. Air Force Manuals

TO 1-1B-40	Handbook of Weight and Balance Data
TO 1C-5A-9	Loading Instructions USAF Series C-5 Aircraft

NOTE

Air Force Technical Orders that have not been integrated into the Department of the Army publications system may be requisitioned through the Adjutant General Office in accordance with AR 310-71.

7. Other Publications and Source of Procurement

Association of American Railroads Rules Governing the Loading of COMMODITIES ON Open Top Cars

Section No. 1 – General Rules

Section No. 6– Rules Governing the Loading of Department of Defense Material

Secretary

Mechanical Division

Association of American Railroads

ATTN: J. H. Bean

59 E. Van Buren St.,

Water Carriers' Tariff No. 27 or reissues thereof — Regulations Governing the Transportation or Storage of Explosives or Other Dangerous Articles or Substances, and Combustible Liquids on Board Vessels.

R. M. Graziano, Agent

American Railroads Building

1920 L. St. N. W.

Washington, D. C. 20036

Motor Carriers' Explosives and Dangerous Articles Tariff No. 15 or reissues thereof – Department of Transportation Regulations Governing Transportation Regulations Governing Transportation of Hazardous Materials by Motor, Rail and Water Including Specifications for Shipping Containers.

Richard H. Hinchcliff, Issuing Officer

1616 P Street, N. W.

Washington, D. C. 20036

8. Department of Transportation

Special Permit No. 3498

Commander

Military Traffic Management Command

ATTN: MTMC-SS

Washington, D. C. 20315

QUESTIONNAIRE
TM 55-2350-217-15-1

1. The purpose of this questionnaire is to determine the use of this manual and to obtain suggestions for its improvement.
2. As a user you are asked to complete and mail the questionnaire within 6 months of the manual publication date. Remove the page, fold and fasten it. The questionnaire is preaddressed on the reverse and requires no postage. Your cooperation is appreciated.

Please circle the appropriate answer or provide comment to the following questions:

1. Show your name (optional), grade, organization, address, and job title.
2. Manual was received 0 - 1 - 2 - 3 - 4 - 5 - 6 months after publication date.
3. How often is the manual used? Daily, weekly, monthly, never.
4. For what purpose was manual used?
 - a. Dimensional and characteristics information.
 - b. Loading guidance.
 - c. Tiedown procedures.
 - d. Other (identify).
5. What chapter(s) is(are) most useful?
1 - 2 - 3 - 4 - 5 - 6 - 7 - All - None
6. Are the manual appendices adequate? Yes No
7. Are the tables and figures comprehensible and easy to follow? Yes No
8. Is the manual of any assistance to you or your organization? Yes No
9. Does the manual provide practical guidance to personnel responsible for loading and shipping of the identified items? Yes No
10. Which mode(s) of transportation is(are) used most frequently for movement of subject items?

CONUS	Air	Hwy	Rail	Water
OVERSEAS	Air	Hwy	Rail	Water
11. Has the transportability guidance outlined in this manual resulted in the use of a mode(s) not previously used? Yes No
12. Are the loading and tiedown procedures used by:
 - a. Your organization Yes No
 - b. Commercial carriers Yes No
 - c. Other military carriers Yes No

DEPARTMENT OF THE ARMY
Military Traffic Management Command
Transportation Engineering Agency
P.O. Box 6276
Newport News, Virginia 23606

POSTAGE AND FEES PAID
DEPARTMENT OF THE ARMY
DoD 314



OFFICIAL BUSINESS
PENALTY FOR PRIVATE USE \$300

MTT-TRP

Director
Military Traffic Management Command
Transportation Engineering Agency
ATTN: MTT-TRP, P.O. Box 6276
Newport News, Virginia 23605

- - - - -Fold here - then fasten at top- - - - -

13. The manual:
- | | | |
|---|-----|----|
| a. Provides information not previously available? | Yes | No |
| b. Supplements related manuals? | Yes | No |
14. Does this manual contradict other published manuals? Yes No
- If answer is Yes, which manuals?
15. What additional transportability guidance manuals are needed? (Specify)
16. What would you like to see added, improved, deleted, or changed in the manual?

Signature (optional)

By Order of the Secretary of the Army:

Official:

VERNE L. BOWERS

*Major General, United States Army,
The Adjutant General.*

FRED C. WEYAND

*General, United States Army,
Chief of Staff.*

Distribution:

To be distributed in accordance with DA Form 12-34B, (qty rqr block No. 159). Requirements for Transportability Guidance: Guns, Howitzers, and Rifles.

DEPARTMENT OF THE ARMY
US ARMY AG PUBLICATIONS CENTER
2800 EASTERN BOULEVARD
BALTIMORE MARYLAND 21220
OFFICIAL BUSINESS
PENALTY FOR PRIVATE USE \$300

POSTAGE AND FEES PAID
DEPARTMENT OF THE ARMY
DOD 314

SPECIAL FOURTH CLASS BOOK
RATE

